

Standard Purchasing Resolution 2: Award to Sole Bidder Meeting Specifications – Department of Public Works Window Replacement – Parks Maintenance Garage and Main Facility

Resolution #2020-09-138-J-4b

RESOLVED, That Troy City Council hereby **AWARDS** a contract for replacement windows at the Department of Public Works Parks Maintenance Garage and Main Facility; as per bid specifications to the sole bidder meeting specifications, *H&H Glass & Metal, Inc. of Detroit, MI*, for an estimated total cost of \$48,906 at unit prices contained in the bid tabulation opened September 3, 2020; a copy of which shall be **ATTACHED** to the original Minutes of the meeting, with a 10% contingency of \$4,900 for an estimated grand total amount of \$53,806 not to exceed budgetary limitations.

BE IT FURTHER RESOLVED, That the award is **CONTINGENT** upon contractor's submission of properly executed contract documents, including insurance certificates and all other specified requirements.

PURCHASE ORDER

No. 2021-00000414
 DATE: 09/24/2020
 PAGE: 1 of 1
 FOB DESTINATION

Ship To

CITY OF TROY
 Building Operations
 4695 ROCHESTER ROAD
 TROY, MI 48085

Bill To

CITY OF TROY
 Building Operations
 4693 ROCHESTER ROAD
 TROY, MI 48085

COUNCIL RESOLUTION
 2020-09-138-J-4b

VENDOR NO. 175545

Vendor

H&H GLASS & METAL INC
 13780 NELSON ST
 DETROIT, MI 48227

QUANTITY	UNIT	DESCRIPTION	UNIT COST	TOTAL COST
3	Each	Furnish and Install Windows per Proposal A-1	3,755.0000	\$11,265.00
1	Each	Furnish and Install Frosted Glass Window per Proposal A-1	4,589.0000	\$4,589.00
6	Each	Install 48" x 24" Hopper Style Vent Window per Proposal A-2	1,192.0000	\$7,152.00
20	Each	Furnish and Install 24" x 72" Windows per Proposal B-1	625.0000	\$12,500.00
20	Each	Bronze Tint Insulated Glazing Install Hopper Style Vent Per Proposal B-2	670.0000	\$13,400.00

Entered By: MaryBeth Murz

\$48,906.00

Special Instructions:

CITY COUNCIL AWARD DATE: 9/21/2020. CERTIFICATE OF INSURANCE and ENDORSEMENT SHALL BE ON FILE FOR DURATION OF PROJECT AND INSTALL.

TERMS & CONDITIONS

1. Purchases of Municipalities are exempt from State Sales and Federal Excise Taxes.
2. Prior to acceptance, vendor agrees to provide City with information under the Right-to-Know Law, P.A. 1986, No. 80, and fully comply with all terms and conditions of the Michigan Occupational Safety and Health Act, MCL 408.1001, et seq. including vendor shall provide City with an "MSDS". Vendor also agrees to be responsible for all required labeling.
3. In cases of emergency/disaster, the City can purchase up to six(6) times the order amount for a period of six(6) months at the price contained in the contract.
4. Purchase Orders are signed electronically based upon computer generated "on-line" authorized approvals. Authentic signatures are on file in the City of Troy Purchasing Department.

NOTICE: The City could put the vendor on notice that vendors will be held financially responsible for any claims or awards made against the City as a result of the vendor's action. If the City has to defend the initial lawsuit, the City will bring in the vendor as a co-defendant or sue the vendor, either as the result of settling a claim or the conclusion of the lawsuit.

I HEREBY CERTIFY THAT THIS ORDER IS PROPERLY AUTHORIZED AND APPROVED.

MaryBeth Murz

CITY OF TROY
 BID TABULATION
 REPLACEMENT WINDOWS

VENDOR NAME:	H&H Glass & Metal Inc.
CITY:	Detroit, MI
CHECK #:	1620418470
CHECK AMOUNT:	\$4,250.00

PROPOSAL: Purchase and Install Replacement Windows for the City of Troy Department of Public Works		
Description	Unit Price	Extension
PROPOSAL A-1: Demo and dispose of four (4) existing 61" x 197" steel sash windows. Install 2" x 4.5" dark bronze commercial aluminum framing splitting 3 times and glazed with bronze tint insulated glazing. Price shall include all Materials and Labor.	Qty: 3) \$3,755	\$11,265.00
	Qty: 1) \$4,589 Frosted Glass	\$4,589.00
PROPOSAL A-2: Install 48" x 24" hopper style vent window.	\$1,192.00	\$4,768.00
PROPOSAL B-1: Demo and dispose of 20 existing 24" x 72" aluminum framed windows. Install 2" x 4.5" clear anodized aluminum framing glazed with clear insulated glazing. Price shall include all Materials and Labor.	\$625.00	\$12,500.00
PROPOSAL B-2: Bronze tint insulated glazing Install hopper style vent window.	\$670.00	\$13,400.00
Total Cost:		\$46,522.00

NOTE: Pricing shall include all delivery costs, handling, and installation.

Completion Schedule can be met:	Y or N	As Specified
Descriptive Literature provided:	Y or N	Y
Attended Site Inspection:	Y or N	Y - 08/25/2020
Can Meet Delivery Schedule:	Y or N	Y
Hours of Operation:		9AM - 3PM
Contact Phone #:		313-646-6000
Warranty:		Michigan
Subcontractors Requirement met:	Y or N	Y
References:	Y or N	Y
Can Meet Insurance:	Y or N	Y
Payment Terms:		30 days
Exceptions:	Y or N	N
Acknowledgement:	Y or N	Y
Forms:	Y or N	Y

Attest:
 (*Bid Opening conducted via a Go-To Meeting)
 Dennis Trantham
 Kristine Kallek
 Jackie Ahlstrom
 Jodi Kolakowski

MaryBeth Murz,
 Purchasing Manager



**City of Troy
Electronic Bid Proposal**

ITB-COT 21-07
Page 1 of 6

The undersigned proposes to purchase and install **Replacement Windows for the City of Troy Department of Public Works**, in accordance with the specifications, which are to be considered an integral part of this proposal, at the following prices:

COMPANY NAME: H&H Glass & Metal Inc

Description	Unit Price	Extension
PROPOSAL A-1: Demo and dispose of four (4) existing 61" x 197" steel sash windows. Install 2" x 4.5" dark bronze commercial aluminum framing splitting 3 times and glazed with bronze tint insulated glazing. The lower half of the east window should receive frosted glazing in the restroom area. Price shall include all Materials and Labor.	QT: 3) \$3,755 QT: 1) \$4,589 Frosted Glass ^	\$11,265 \$4,589
PROPOSAL A-2: Install 48" x 24" hopper style vent window.	\$1,192	\$4,768
PROPOSAL B-1: Demo and dispose of 20 existing 24" x 72" aluminum framed windows. Install 2" x 4.5" clear anodized aluminum framing glazed with clear insulated glazing. Price shall include all Materials and Labor.	\$625	\$12,500
PROPOSAL B-2: Bronze tint insulated glazing Install hopper style vent window.	\$670	\$13,400
Total Cost:		

NOTE: Pricing shall include all delivery costs, handling, and installation.

*** BID AS SPECIFIED. APPROVED ALTERNATES SHALL BE ACCEPTED.**

The undersigned, as bidder, declares that he/she has examined the specifications, including related documents. Being familiar with the conditions in the City of Troy and the type of work required, the bidder hereby proposes to furnish all labor, materials, equipment and supplies, to provide the services specified in the bid proposal documents, at the prices stated below. These prices are to cover all expenses incurred in performing the work required:

Proposals A, and B shall be completed no later than **December 4, 2020.**

NOTE: Asbestos Testing for the steel windows was performed on July 22, 2020. Results came back negative. The report is available for bidders upon request.

UNIT PRICES:

Unit prices prevail. The City of Troy Purchasing Department will correct all mathematical errors.

DESCRIPTIVE LITERATURE:

Please attach descriptive or pertinent literature relevant to your company's bid proposal at the time of bid submission. It is attached and marked proposal # 826 for your identification.

ADDITIONAL INFORMATION:

For questions about the specifications, please contact **Mr. Dennis Trantham**, Facilities & Grounds Operations Manager at **(248) 524-3503**, between the hours of 8:00 AM and 4:30 PM, Monday through Friday.

DELIVERY:

All items are to be F.O.B. delivered, freight paid with inside delivery, to the Troy Department of Public Works, 4693 Rochester Road, Troy, MI 48085, ATTN: Dennis Trantham.

SITE INSPECTION:

Any prospective bidders is required to schedule an on-site appointment in order to inspect the existing windows to be removed before bids are submitted. Please contact Dennis Trantham, Facilities & Grounds Operations Manager at (248) 524-3503, between the hours of 8:00 am and 4:30 pm, Monday through Friday to make an appointment.

- Our Company visited the site on: 8/25/2020
- Our company did not visit the site.

DELIVERY SCHEDULE:

All windows shall be delivered and installed at the Troy Department of Public Works **by December 4, 2020**. It will be the successful bidder's responsibility to work with the department representative to establish an acceptable delivery and installation schedule. Installation shall be within two (2) business days after receipt of the windows at the City's location. The windows should not be delivered to the City's site unless the windows are to be installed and made ready for use within the above parameters. The City of Troy is the only party to this contract that may authorize amendment to this schedule.

- Our Company can meet this delivery and installation schedule
- Our company cannot meet this delivery and installation schedule but offers: _____

DOWN-PAYMENTS OR PREPAYMENTS:

Any bid proposal submitted which requires a down-payment or prepayment prior to delivery and full acceptance of the item(s) as being in conformance with specifications will not be considered for award.

AWARD:

The evaluation and award of this bid shall be a combination of factors, including but not limited to: cost, professional competence, windows as specified, warranties, and the correlation of the proposal submitted to the needs of the City of Troy.

The City of Troy reserves the right to award this bid to the lowest responsible bidder(s) meeting specifications for the purchase of Replacement Windows or to combine the items in whatever manner is deemed to be in the City of Troy's best interest; to reject low bids which have major deviations from the specifications; to accept a higher bid which has only minor deviations.

COMPANY NAME: H&H Glass & Metal Inc

LOCAL PREFERENCE:

The City of Troy reserves the right to award a contract to a local business, one which pays City of Troy taxes (real and/or personal), if the bid of a local vendor is within 5% of the lowest responsive and responsible non-local bidder, then the local vendor is given one chance to match the low bid.

PURCHASE ORDER:

After approval of the successful bidder(s) by the Troy City Council, the purchase order issued from the City of Troy will create a bilateral contract between the parties and commit the successful bidder(s) to perform the contract in accordance with specifications. The Purchase orders will be released upon the City's acceptance of the specified insurance. A contract document/ agreement will not be issued.

CONTRACT FORMS:

Bidders should complete and sign the Legal Status of Bidder, Non-Collusion Affidavit, Certification regarding Debarment, the Certification regarding "Iran Linked Business" and the Familial Disclosure Forms and return with your bid proposal. Due to COVID-19 restrictions the City is waiving Notary requirements; but note that all forms must be signed and dated.

CONTACT INFORMATION:

Hours of Operation: 9:00 am - 3:00 pm Contact Phone #: 313-646-6000

WARRANTY:

State Warranty: Michigan

SUBCONTRACTORS:

Service and warranty work cannot be subcontracted. The successful bidders(s) must be able to service and repair the windows bid with in-house personnel.

Our Company complies with this requirement: (Circle one) YES or NO

REFERENCES:

Please submit a list of **THREE CUSTOMERS** that your company has replaced windows. Include the name of the company, the address, phone number, contact person and email. The references are as follows:

COMPANY	ADDRESS	CONTACT PERSON	EMAIL	PHONE	YEAR PURCHASED
Obrien Construction	966 Livernois Rd Troy, MI 48083	Andrew	andrewd@obrienc.com	248-334-2470	2019
George Pastor and sons	34018 Beacon Livonia, MI 48150	Bassem	ssaleh@ghpastor.com	734-522-3800	2020
Ronnisch construction Group	4327 Delemere Court Royal Oak, MI 48073	Bridgette	brironnisch@ronnisch.com	248-549-1800	2019

COMPANY NAME: H&H Glass & Metal Inc

INSURANCE:

Insurance requirements shall be in accordance with the attached **SAMPLE INSURANCE CERTIFICATE** and **ENDORSEMENT**. The required Insurance Certificate and Endorsement must be submitted to the city within 5 days of the verbal/ electronic request after the bid award. The Insurance Certificate and Endorsement may be faxed to the Purchasing Office at (248) 619-7608, and is the only bid document accepted in this format.

The contractor, or any of their subcontractors, shall not commence work under this contract until they have obtained the insurance required, and shall keep such insurance in force during the entire life of this contract. All coverage shall be with insurance companies licensed and admitted to business in the State of Michigan and acceptable to the City of Troy. The requirements below should not be interpreted to limit the liability of the Contractor. All deductibles and self-insured retentions (SIR's) are the responsibility of the Contractor.

- We can meet the specified insurance requirements.
- We cannot meet the specified insurance requirements.

- We do not carry the specified limits but can obtain the additional insurance coverage of \$ _____, at the cost of \$ _____.

NOTE: Please note the amendments on a sample insurance certificate and attach it to your bid proposal.

- Our proposal is reduced by \$ _____ if we lower the requirement to \$ _____.

NOTE: Please note the amendments on a sample insurance certificate and attach it to your bid proposal.

IMPORTANT: A Certificate of Insurance on an ACORD Form showing present coverage as well as the required endorsements **SHALL** be attached to the proposal document at the time of submission of the proposal to the Office of the City Clerk.

NOTE: Failure on the part of any bidder to contact his/her insurance carrier to verify that the insurance carried by the bidder meets City of Troy specifications may result in this proposal being completed incorrectly.

OTHER: Sole proprietors must execute a certificate of exemption from Worker's Compensation requirements or provide proof of Worker's Compensation Insurance. All coverage shall be with insurance carriers licensed and admitted to do business in Michigan in accordance with all applicable statutes of the State of Michigan and acceptable to the City of Troy.

INSURANCE VERIFICATION:

A bidder shall complete the above portion, which details additional costs that may be incurred for specified coverage without purchasing the additional coverage prior to bid submission.

WORKERS' COMPENSATION INSURANCE, including Employers' Liability Coverage, in accordance with all applicable statutes of the State of Michigan.

COMMERCIAL GENERAL LIABILITY INSURANCE on an "Occurrence Basis" with limits of liability not less than \$1,000,000.00 per occurrence and aggregate. Coverage shall include the following extensions: (A) Contractual liability; (B) Products and Completed Operations; (C) Independent Contractors Coverage; (D) Broad Form General Liability Extensions or equivalent, if not already included; (E) Deletion of all Explosion, Collapse, and Underground (XCU) Exclusions, if applicable.

COMPANY NAME: H&H Glass & Metal Inc

AUTOMOBILE LIABILITY, including Michigan No-Fault Coverages, with limits of liability not less than \$1,000,000.00 per occurrence combined single limit for Bodily Injury, and Property Damage. Coverage shall include all owned vehicles, all non-owned vehicles, and all hired vehicles.

ADDITIONAL INSURED:

Commercial General Liability and Automobile Liability, as described in the attached SAMPLE shall include an Additional Insured Endorsement stating the following shall be ***Additional Insureds***: The City of Troy including all elected and appointed officials, all employees and volunteers, all boards, commissions, and/or authorities and council members, including employees and volunteers thereof. It is understood and agreed by naming the City of Troy as additional insured, coverage afforded is considered to be primary and any other insurance the City of Troy may have in effect shall be considered secondary and/or excess.

CANCELLATION NOTICE:

All policies, as described above, shall include an endorsement stating that it is understood and agreed that Thirty (30) days, Ten (10) days for non-payment of premium, Advance Written Notice of Cancellation, Non-Renewal, Reduction, and/or Material Change shall be mailed to:

City of Troy
Purchasing Manager
500 West Big Beaver
Troy, MI 48084

PROOF OF INSURANCE COVERAGE:

The Contractor shall provide the City of Troy, at the time that the contracts are returned by him/her for execution, a Certificate of Insurance as well as the required endorsements. In lieu of required endorsements, if applicable, a copy of the policy sections where coverage is provided for additional insured and cancellation notice would be acceptable. Copies or certified copies of all policies mentioned above all shall be furnished, if so requested.

If any of the applicable coverages expire during the term of this contract, the Contractor shall deliver renewal certificates and endorsements to the City of Troy at least ten (10) days prior to the expiration date.

COMPANY NAME: H&H Glass & Metal Inc

SIGNATURE PAGE

PRICES:

Prices shall remain firm for 120 days or bid award, whichever comes first, except the successful bidder(s) whose prices shall remain firm through delivery, installation, and final acceptance as operational in accordance with the bid specifications.

SIGNATURE OF AUTHORIZED COMPANY REPRESENTATIVE: Nick Etterman

NOTE:

The undersigned has checked carefully the bid figures and understands that he/she shall be responsible for any error or omission in this bid offer and is in receipt of all addenda as issued.

TAX ID#: 20-8622949

COMPANY NAME: H&H Glass & Metal Inc

ADDRESS 13780 Nelson CITY Detroit STATE MI ZIP 48227

PHONE NUMBER 313-646-6000 FAX NUMBER 313-646-2939

REPRESENTATIVE'S NAME Nick Etterman
(Print)

SIGNATURE OF AUTHORIZED COMPANY REPRESENTATIVE Nick Etterman

PAYMENT TERMS: 30 days WARRANTY: one year

E-MAIL: haiddr@yahoo.com COMPLETION DATE: AS SPECIFIED

EXCEPTIONS:

Any exceptions, substitutions, deviations, etc., from the City specifications and this proposal must be stated below. The reason(s) for the exceptions, substitutions, and/or deviations are an integral part of this bid proposal offer:

Check this box if your bid is not to be broken up by item and based on an all or none award.

ACKNOWLEDGEMENT:

I, Nick Etterman, certify that I have read the *Instructions to Bidders* (2 Pages) and that the bid proposal documents contained herein were obtained directly from the City's Purchasing Department or MITN website, www.mitn.info and is an official copy of the Authorized Version.

SIGNATURE OF AUTHORIZED COMPANY REPRESENTATIVE: Nick Etterman

IMPORTANT: All City of Troy purchases require a SAFETY DATA SHEET, where applicable, in compliance with the MIOSHA "Right to Know" Law. Please include a copy of any relevant SDS at the time of bid submission.

U.S. FUNDS: All prices quoted are to be in U.S. Currency.



13780 Nelson Dr., Detroit, MI 48227

haiddr@yahoo.com

(313)646-6000 Fax: (313)646-2939

Proposal #826

Date: 9/1/2020

TO: **City of Troy**
(248) 524-3503

Project Location: City of Troy Department of Public Works
4693 Rochester Road
Troy, MI 48085

H & H Glass & Metal Inc. is pleased to submit a proposal for the above-mentioned project. We will demo, furnish, and install the following items as listed below:

A-1:

Aluminum Framed Storefronts:

- Aluminum by Oldcastle BE - FG3000 non-thermal
- 2" x 4 1/2" Dark Bronze finish
- Split 3 times
- Qty 4) 61" x 197"

Glazing per approved samples:

- 1" Insulated Bronze tint
- Lower half of East window to be 1" Insulated frosted

Sealant/Caulking:

- As it relates to the above sections

Total for A-1:\$ 15,854

A-2 (WINDOWS ONLY):

Hopper Style Vent Windows:

- Vent windows to be RAMCO TB2500 with insect screen and lever handle
- Qty 4) 48" x 24" (each elevation will have one vent window)
- Thermally broken, dark bronze finish

Glazing per approved samples:

- 1" Insulated Bronze tint
- Lower half of East window to be 1" Insulated frosted

Sealant/Caulking:

- As it relates to the above sections

Total for A-2:\$ 4,768

B-1:

Aluminum Framed Storefront:

- Aluminum by Oldcastle BE – FG3000 non-thermal
- 2" x 4 1/2" Clear anodized finish
- Qty 20) 24" x 72"

Glazing per approved samples:

- 1" Clear Insulated

Sealant/Caulking:

- As it relates to the above sections

Total for B-1:\$ 12,500

B-2 (WINDOWS ONLY):

Hopper Style Vent Windows:

- Vent windows to be RAMCO TB2500 with insect screen and lever handle
- Qty 20) 24" x 17" (each elevation will have one vent window)
- Thermally broken, clear anodized finish

Glazing per approved samples:

- 1" Insulated Bronze tint

Sealant/Caulking:

- As it relates to the above sections

Total for B-2:\$ 13,400

Proposal based on work during normal daylight hours

City of Troy: Rear Building Proposal A-1

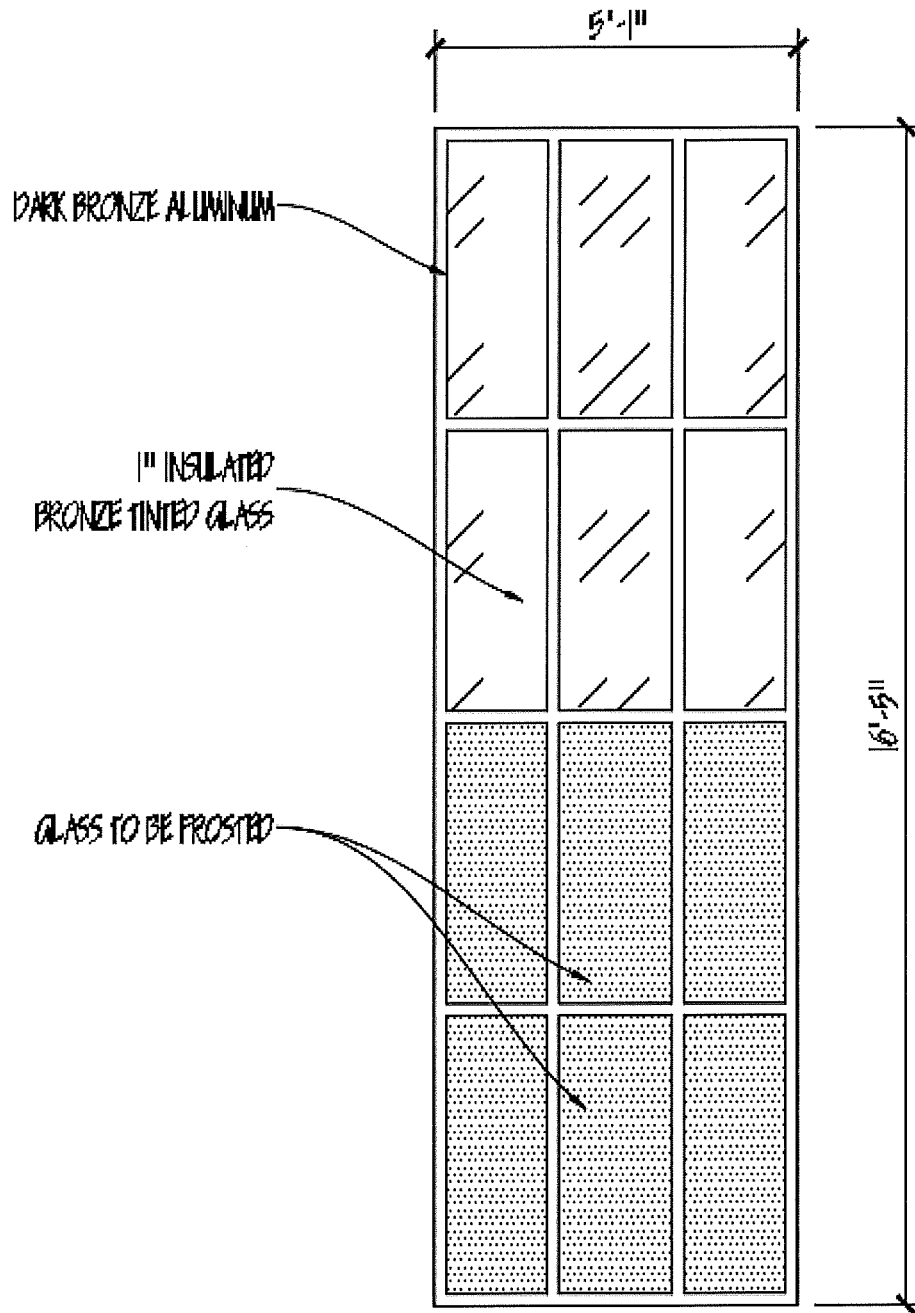

City of Troy: Rear Building Proposal A-1

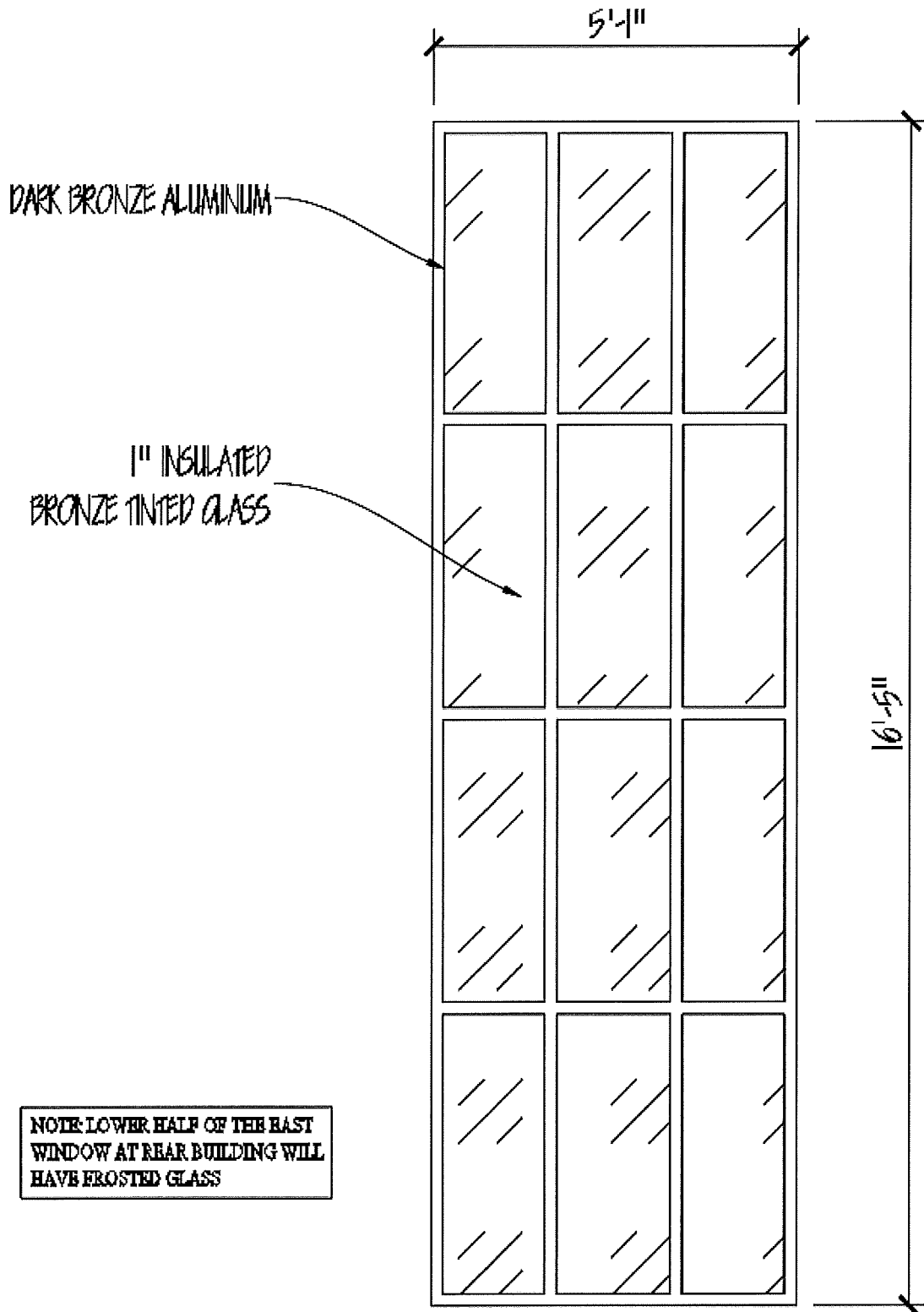

NOTE: LOWER HALF OF THE EAST WINDOW AT REAR BUILDING WILL HAVE FROSTED GLASS

City of Troy: Rear Building Proposal A-2

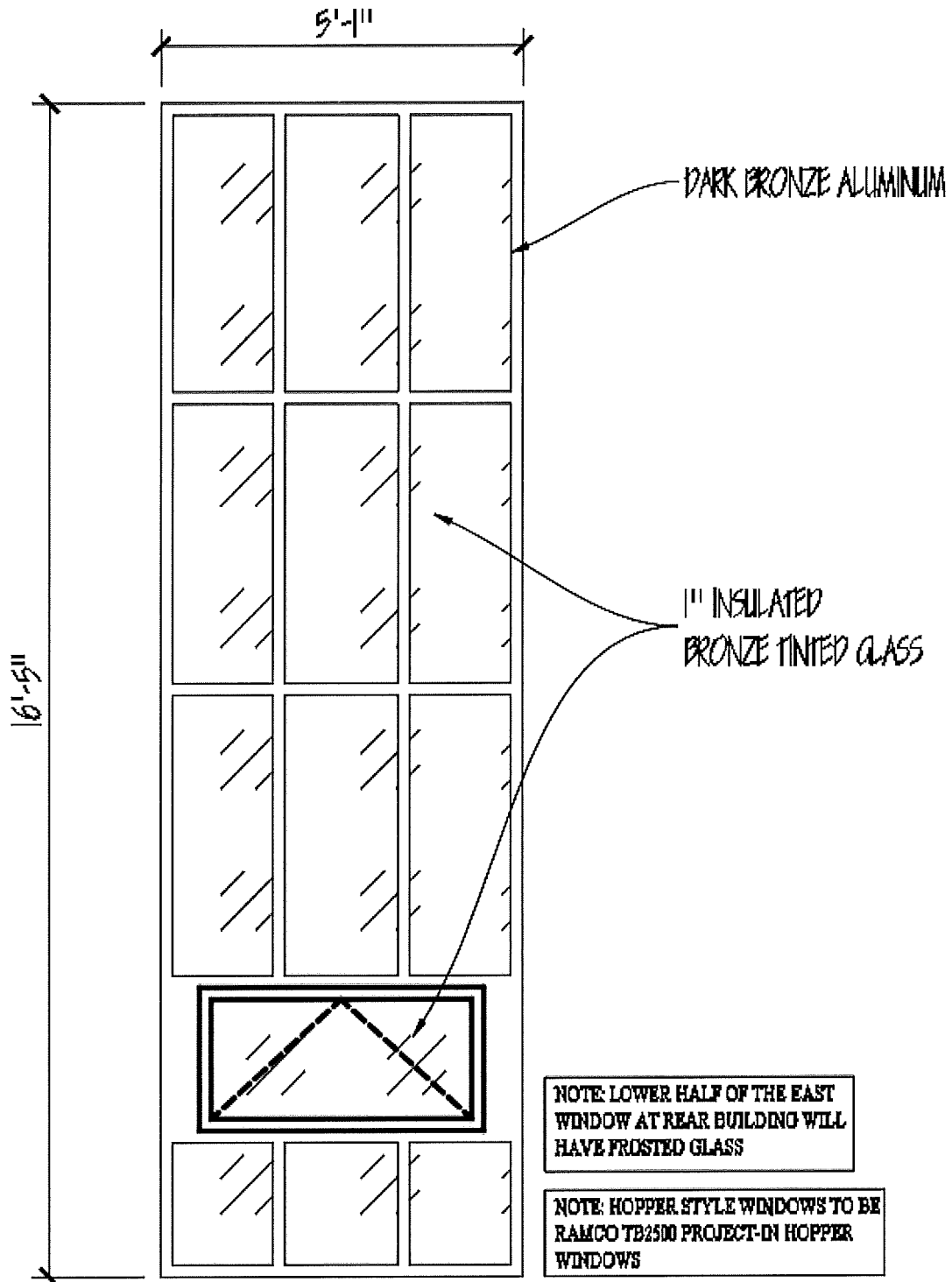

City of Troy: Rear Building Proposal A-2 *Alternate*
(Price upon request)

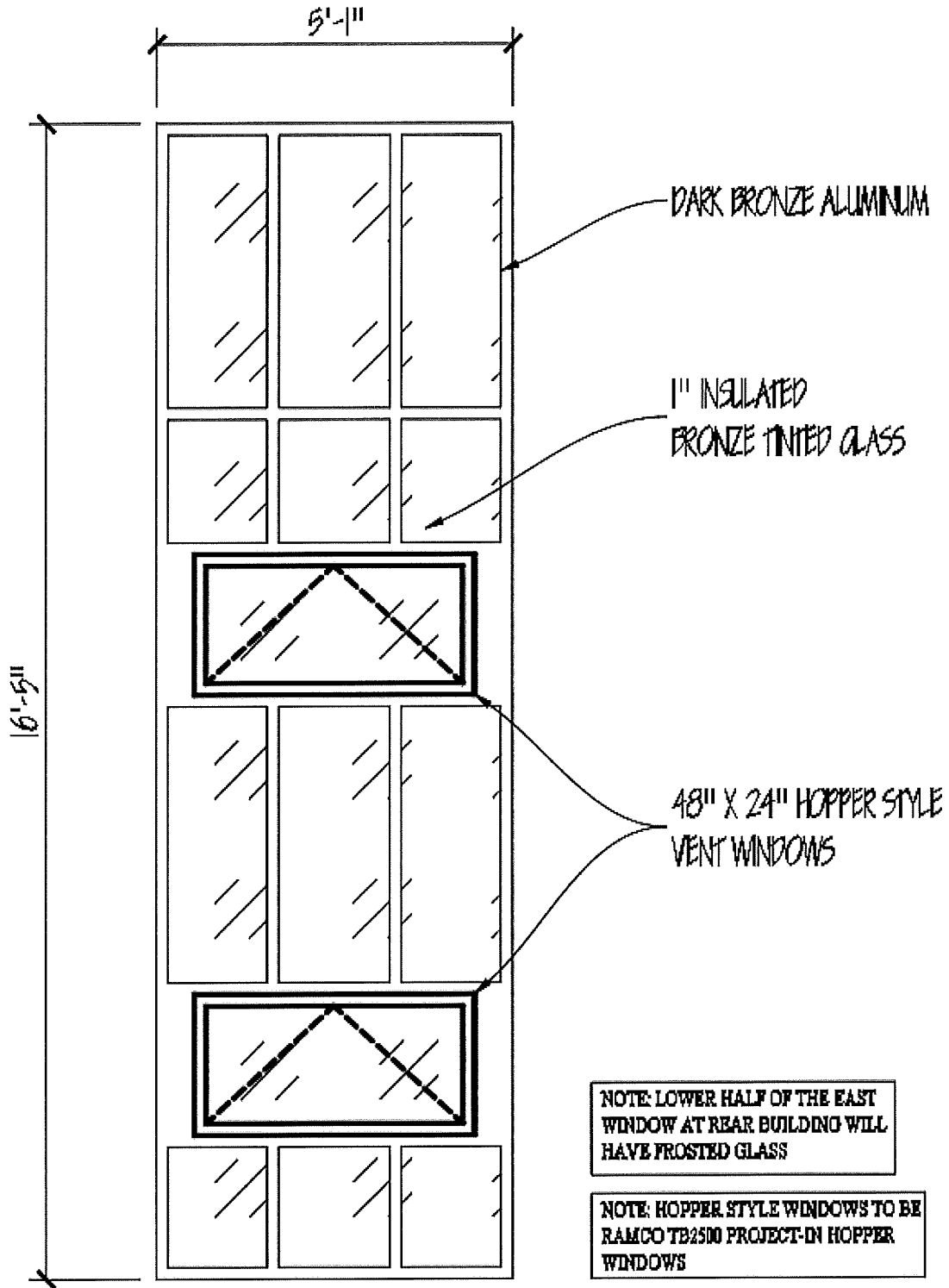

City of Troy: Front Building Proposal B-1

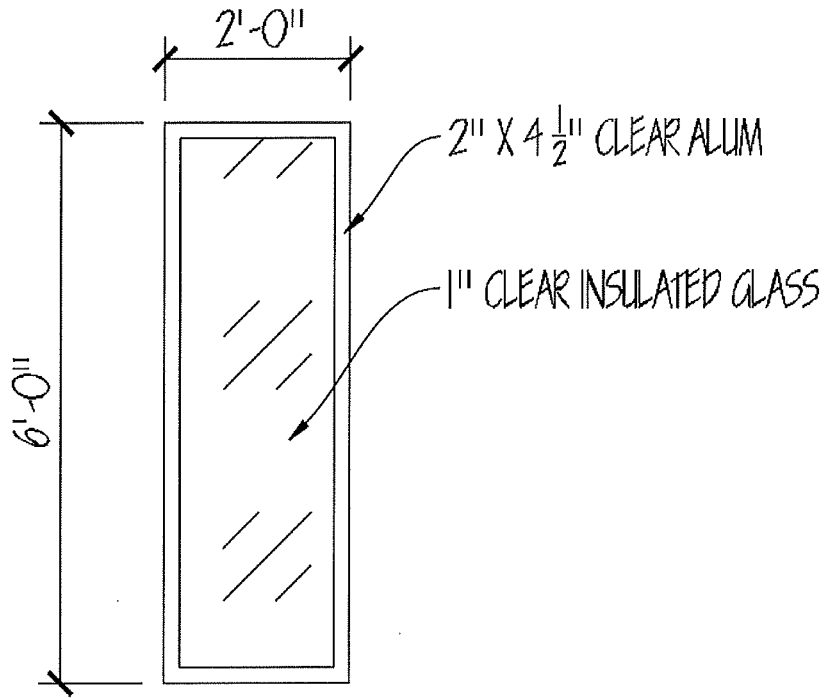

City of Troy: Front Building Proposal B-2

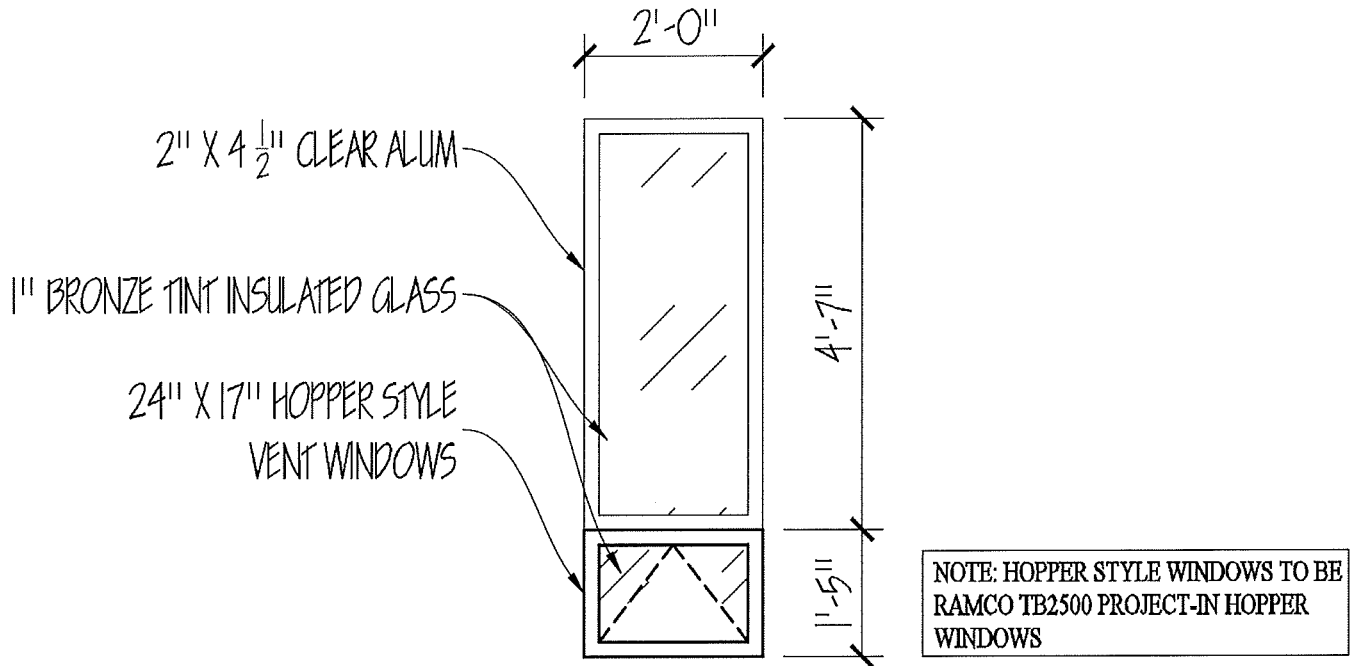



RELIABLE ARCHITECTURAL METALS COMPANY
 9751 ERWIN STREET
 DETROIT, MI 48213
 PH: 800.445.0263 FAX: 313.924.8977

2 1/2" TB-2500
 WINDOW ELEVATIONS
 (1" GLAZING)

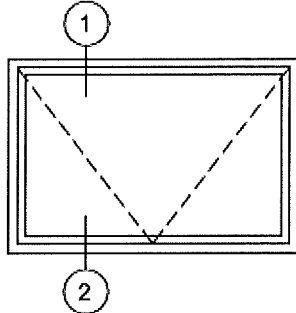

HOPPER
 PROJECT IN
 CAM HANDLE AT TOP / HINGE AT BOTTOM

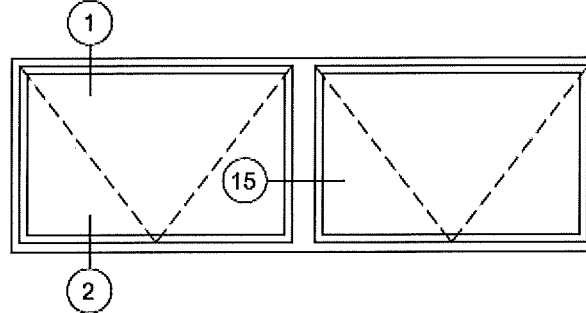

DOUBLE HOPPER

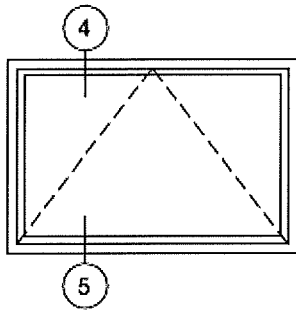

AWNING
 PROJECT OUT
 CAM HANDLE AT BOTTOM / HINGE AT TOP

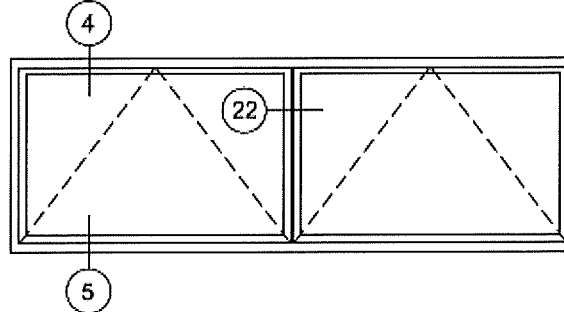

DOUBLE AWNING

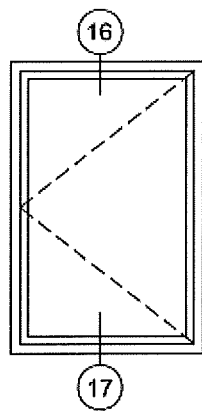

CASEMENT

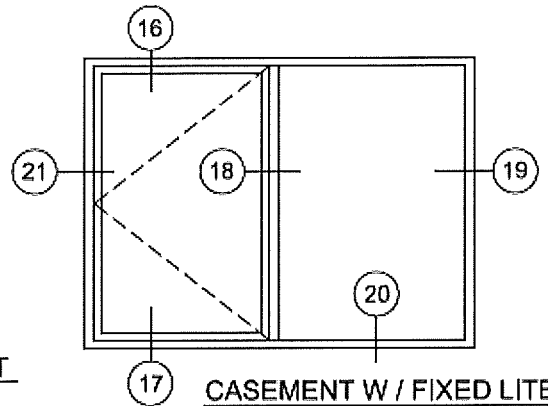

CASEMENT W / FIXED LITE

www.ramcometals.com

- Lead time for glass and aluminum frames 2 weeks after field measurement
- RAMCO TB2500 lead time 4 weeks

Respectfully Submitted
 H&H Glass & Metal, Inc.



Legal Status of Bidder:

The Bidder shall fill out the appropriate form and strike out the other two:

A **corporation** duly organized and doing business under the laws of the State of Michigan
for whom Nick Etterman, bearing the office title of Estimator,
whose signature is affixed to this proposal, is duly authorized to execute contracts.

A **partnership**, all members of which, with addresses, is:

_____	_____
_____	_____
_____	_____
_____	_____
_____	_____
_____	_____

AN **INDIVIDUAL**, WHOSE SIGNATURE IS AFFIXED TO THE PROPOSAL:



CITY OF TROY
OAKLAND COUNTY, MICHIGAN
NON-COLLUSION AFFIDAVIT

TO WHOM IT MAY CONCERN:

Nick Etterman, being duly sworn deposed, says that he/she
(Print Full Name)

is Estimator. The party making the foregoing proposal or bid,
(State Official Capacity in Firm)

that such bid is genuine and not collusion or sham; that said bidder has not colluded, conspired, connived, or agree, directly or indirectly, with any bidder or person, to put in a sham bid or to refrain from bidding and has not in any manner directly or indirectly sought by agreement or collusion, or communication or conference, with any person to fix the bid price or affiant or any other bidder, or to fix any overhead, profit, or cost element of said bid price, or that of any other bidder, or to secure the advantage against the City of Troy or any person interested in the proposed contract; and that all statements contained in said proposal or bid are true.

Nick Etterman
SIGNATURE OF PERSON SUBMITTING BID

NOTARY'S SIGNATURE

Subscribed and sworn to before me this _____ day of _____, 20__ in and for _____
_____ County.

My commission expires:



**CERTIFICATION REGARDING
DEBARMENT, SUSPENSION, AND OTHER RESPONSIBILITY MATTERS**

The prospective participant certifies, to the best of its knowledge and belief, that it and its principals:

1. Are not presently debarred, suspended, proposed for debarment, declared ineligible, or voluntarily excluded from participation in transactions under any non-procurement programs by any federal, state or local agency.
2. Have not, within the three year period preceding, had one or more public transactions (federal, state, or local) terminated for cause or default; and
3. Are not presently indicted or otherwise criminally or civilly charged by a government entity (federal, state, or local) and have not, within the three year period preceding the proposal, been convicted of or had a civil judgment rendered against it:
 - a. For the commission of fraud or a criminal offense in connection with obtaining, attempting to obtain, or performing a public transaction (federal, state, or local), or a procurement contract under such a public transaction;
 - b. For the violation of federal, or state antitrust statutes, including those proscribing price fixing between competitors, the allocation of customers between competitors, or bid rigging; or
 - c. For the commission of embezzlement, theft, forgery, bribery, falsification or destruction of records, making false statements, or receiving stolen property.

I understand that a false statement on this certification may be grounds for the rejection of this proposal or the termination of the award. In addition, the general grant of this authority exists within the City's Charter, Chapter 12, Section 12.2- Contracts.

[X] I am able to certify to the above statements.

H&H Glass & Metal Inc

Name of Agency/Company/Firm *(Please Print)*

Nick Etterman

Name and title of authorized representative *(Please Print)*

Signature of authorized representative

Date

[] I am unable to certify to the above statements. Attached is my explanation.



**VENDOR CERTIFICATION
THAT IT IS NOT AN
"IRAN LINKED BUSINESS"**

Pursuant to Michigan law, (the Iran Economic Sanctions Act, 2012 PA 517, MCL 129.311 et seq.), before accepting any bid or proposal, or entering into any contract for goods or services with any prospective Vendor, the Vendor must first certify that it is not an "IRAN LINKED BUSINESS", as defined by law.

Vendor	
Legal Name	H&H Glass & Metal Inc
Street Address	13780 Nelson
City	Detroit
State, Zip	MI 48227
Corporate I.D. Number/State	Michigan
Taxpayer I.D. #	20-8622949

The undersigned, with: 1.)full knowledge of all of Vendors business activities, 2.)full knowledge of the requirements and possible penalties under the law MCL 129.311 et seq. and 3.) the full and complete authority to make this certification on behalf of the Vendor, by his/her signature below, certifies that: the Vendor is NOT an "IRAN LINKED BUSINESS" as require by MCL 129.311 et seq., and as such that Vendor is legally eligible to submit a bid and be considered for a possible contract to supply goods and/or services to the City of Troy.

Signature of Vendor's Authorized Agent: Nick Etterman

Printed Name of Vendor's Authorized Agent: Nick Etterman

Witness Signature: Zeinab

Printed Name of Witness: Zeinab Jouni



Proposer's Sworn and Notarized Familial Disclosure
(to be provided by the Proposer)

The undersigned, the owner or authorized officer of H&H Glass & Metal Inc (the "Proposer"), pursuant to the familial disclosure requirement provided in the Request for Proposal, hereby represent and warrant, except as provided below, that no familial relationships exist between the owner(s) or any employees of the City of Troy Department of Public works and any member of the City of Troy City Council or City of Troy management.

List any Familial Relationships:

BIDDER:
H&H Glass & Metal Inc

By: Nick Etterman

Its: Estimator

STATE OF MICHIGAN)

)ss.

COUNTY OF _____)

This instrument was acknowledged before me on the ____ day of _____, 2020, by



500 West Big Beaver
Troy, MI 48084
troymi.gov

CITY COUNCIL AGENDA ITEM

Date: September 15, 2020

To: Mark F. Miller, City Manager

From: Robert J. Bruner, Assistant City Manager
Rob Maleszyk, Chief Financial Officer
Lisa Burnham, Controller
Kurt Bovensiepe, Public Works Director
Dennis Trantham, Facilities and Grounds Operations Manager
MaryBeth Murz, Purchasing Manager

Subject: Standard Purchasing Resolution 2: Award to Sole Bidder Meeting Specifications – Department of Public Works Window Replacement – Parks Maintenance Garage and Main Facility

History

Parks Maintenance Garage:

- The windows in the Parks Maintenance Garage are single pane, steel framed, and non-insulated.
- Original to the building circa 1960's.
- Window frames are rusting beyond repair causing the glass to fall out.
- Window replacement was identified for replacement in the Facilities Condition Assessment and Analysis.

DPW Main Building:

- The windows in the south west portion of the main DPW building are original to the facility circa 1975.
- Current windows have non-thermally broken frames and non-insulated glass and window seals are failing.
- Window replacement was identified for replacement in the Facilities Condition Assessment and Analysis.

Purchasing

On September 3, 2020, a bid opening was conducted as required by City Charter and Code for the replacement windows at the Public Works Main Facility and Parks Maintenance Garage. The bid was posted on the Michigan Inter-governmental Trade Network (MITN) website; www.mitn.info. One (1) bid response was received. Below is a detailed summary of potential vendors:



500 West Big Beaver
 Troy, MI 48084
 troymi.gov

CITY COUNCIL AGENDA ITEM

Purchasing (continued)

Companies notified via MITN	200	<p>MITN provides a resourceful online platform to streamline the procurement process, reduce costs, and make it easier and more transparent for vendors to do business with the City of Troy.</p> <p>Active MITN members with a current membership and paying annual dues receive automatic electronic notification which allows instant access to Bids, RFPS and Quote opportunities with the City.</p> <p>Active MITN non-paying members are responsible to monitor and check the MITN website for opportunities to do business with the City.</p> <p>Inactive MITN member status can occur when a company does not renew their account upon expiration. Inactive members cannot be notified of solicitations or access any bid information.</p>
Troy Companies notified via MITN	5	
Troy Companies - Active email Notification	5	
Troy Companies - Active Free	0	
Companies that viewed the bid	13	
Troy Companies that viewed the bid	0	

- *H&H Glass & Metal Inc., of Detroit, MI*, is the sole bidder and meets all bid specifications and is being recommended for the window replacement at the Public Works Main Facility and Parks Maintenance Garage.
- The total cost of the windows includes all delivery costs, handling and installation.

Financial

Funds are budgeted and available in the Public Works Capital Project Fund under Project Number 2021C0045 and 2021C0046 for the 2021 fiscal year. Expenditures will be charged to account number 401.464.7975.900.

Recommendation

City management recommends awarding a contract for the replacement windows at the Public Works Main Facility and Parks Maintenance Garage; as per bid specifications to the sole bidder meeting specifications; *H&H Glass & Metal Inc., of Detroit, MI* at prices contained in the bid tabulation opened September 3, 2020 for an estimated total cost of \$48,906 with a 10% contingency of \$4,900 for an estimated grand total amount of \$53,806 not to exceed budgetary limitations.



CERTIFICATE OF LIABILITY INSURANCE

DATE (MM/DD/YYYY)
08/26/2020

THIS CERTIFICATE IS ISSUED AS A MATTER OF INFORMATION ONLY AND CONFERS NO RIGHTS UPON THE CERTIFICATE HOLDER. THIS CERTIFICATE DOES NOT AFFIRMATIVELY OR NEGATIVELY AMEND, EXTEND OR ALTER THE COVERAGE AFFORDED BY THE POLICIES BELOW.

IMPORTANT: If the certificate holder is an ADDITIONAL INSURED, the policy(ies) must have ADDITIONAL INSURED provisions or be endorsed. If SUBROGATION IS WAIVED, subject to the terms and conditions of the policy, certain policies may require an endorsement.

Table with PRODUCER (Karcher Agency Inc.), INSURED (H & H Glass & Metal, Inc.), CONTACT NAME (Gerald J. Stanley), and INSURER(S) AFFORDING COVERAGE (Auto-Owners Insurance Company, Travelers).

COVERAGES CERTIFICATE NUMBER: REVISION NUMBER:

THIS IS TO CERTIFY THAT THE POLICIES OF INSURANCE LISTED BELOW HAVE BEEN ISSUED TO THE INSURED NAMED ABOVE FOR THE POLICY PERIOD INDICATED. NOTWITHSTANDING ANY REQUIREMENT, TERM OR CONDITION OF ANY CONTRACT OR OTHER DOCUMENT WITH RESPECT TO WHICH THIS CERTIFICATE MAY BE ISSUED OR MAY PERTAIN, THE INSURANCE AFFORDED BY THE POLICIES DESCRIBED HEREIN IS SUBJECT TO ALL THE TERMS, EXCLUSIONS AND CONDITIONS OF SUCH POLICIES.

Table with columns for INSR LTR, TYPE OF INSURANCE, POLICY NUMBER, POLICY EFF, POLICY EXP, and LIMITS. Includes rows for Commercial General Liability, Automobile Liability, Umbrella Liab, and Workers Compensation.

DESCRIPTION OF OPERATIONS / LOCATIONS / VEHICLES (ACORD 101, Additional Remarks Schedule, may be attached if more space is required)
CITY OF TROY ARE COVERED AS ADDITIONAL INSURED
JOB: CITY OF TROY DEAPRTMENT OF PUBLIC WORKS 4693 ROCHESTER RD TROY MI 48085

Table with CERTIFICATE HOLDER (CITY OF TROY) and CANCELLATION (SHOULD ANY OF THE ABOVE DESCRIBED POLICIES BE CANCELLED BEFORE THE EXPIRATION DATE THEREOF, NOTICE WILL BE DELIVERED IN ACCORDANCE WITH THE POLICY PROVISIONS.)

THIS ENDORSEMENT CHANGES THE POLICY. PLEASE READ IT CAREFULLY.

BLANKET ADDITIONAL INSURED

This endorsement modifies insurance provided under the following:

COMMERCIAL GENERAL LIABILITY COVERAGE PART

- A.** Under **SECTION II - WHO IS AN INSURED** is amended. The following provision is added. A person or organization is an Additional Insured, only with respect to liability caused, in whole or in part, by "your work" for that Additional Insured by or for you:
1. If required in a written contract or agreement; or
 2. If required by an oral contract or agreement only if a Certificate of Insurance was issued prior to the loss indicating that the person or organization was an Additional Insured.
- B.** **SECTION III - LIMITS OF INSURANCE** is amended. The following provision is added. The limits of liability for the Additional Insured are those specified in the written contract or agreement between the insured and the owner, lessee or contractor or those specified in the Certificate of Insurance, if an oral contract or agreement, not to exceed the limits provided in this policy. These limits are inclusive of and not in addition to the limits of insurance shown in the Declarations.
- C.** **SECTION IV - COMMERCIAL GENERAL LIABILITY CONDITIONS** is amended.
1. The following condition is added to **4. Other Insurance**.
This insurance is primary for the Additional Insured, but only with respect to liability caused,

in whole or in part, by "your work" for that Additional Insured by or for you. Other insurance available to the Additional Insured will apply as excess insurance and not contribute as primary insurance to the insurance provided by this endorsement.

2. The following condition is added.
Other Additional Insured Coverage Issued By Us
If this policy provides coverage for the same loss to any Additional Insured specifically shown as an Additional Insured in another endorsement to this policy, our maximum limit of insurance under this endorsement and any other endorsement shall not exceed the limit of insurance in the written contract or agreement between the insured and the owner, lessee or contractor, or the limits provided in this policy, whichever is less. Our maximum limit of insurance arising out of an "occurrence", shall not exceed the limit of insurance shown in the Declarations, regardless of the number of insureds or Additional Insureds.

All other policy terms and conditions apply.