

CITY COUNCIL MINUTES

June 24, 2024

**Standard Purchasing Resolution 1: Award to Sole Bidder – Acoustic Panel Replacement in the Senior Dining Room at the Troy Community Center**

Resolution #2024-06-085-J-4a

RESOLVED, That Troy City Council hereby **AWARDS** a contract for removal, replacement, and installation of the acoustic panels in the Senior Dining Room at the Troy Community Center, to the sole bidder meeting specifications, *ISCG Inc. of Royal Oak, MI*, for a total estimated price of \$66,240 at unit price as contained in the bid tabulation opened on June 13, 2024, a copy of which shall be **ATTACHED** to the original Minutes of this meeting; not to exceed budgetary limitations.

BE IT FURTHER RESOLVED, That the award is **CONTINGENT** upon the submission of properly executed contract documents, including insurance certificates and all other specified requirements.

# PURCHASE ORDER

No. 2024-00001511  
 DATE: 06/28/2024  
 PAGE: 1 of 1  
 FOB DESTINATION

**Ship To**  
 CITY OF TROY  
 Building Operations  
 3179 LIVERNOIS  
 TROY, MI 48083

**Bill To**  
 CITY OF TROY  
 Building Operations  
 4693 ROCHESTER ROAD  
 TROY, MI 48085

**COUNCIL RESOLUTION**  
 2024-06-085-J-4a

VENDOR NO. 103222

**Vendor**  
 INTERIOR SYSTEMS CONTRACT GROUP  
 612 NORTH MAIN  
 ROYAL OAK, MI 48067

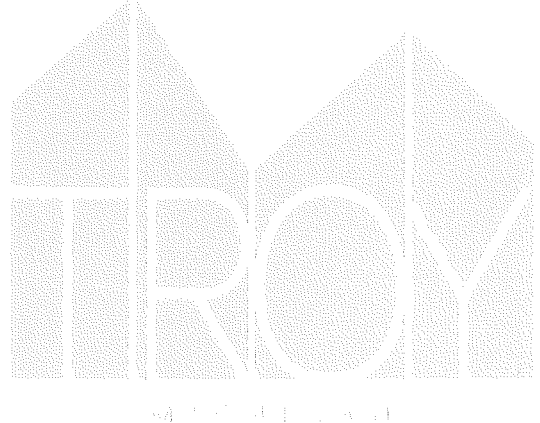
QUANTITY	UNIT	DESCRIPTION	UNIT COST	TOTAL COST
1	Lump Sum	Community Center Senior Dining Acoustic Panels	66,240.0000	\$66,240.00
				

Entered By: Andrew Chambliss

\$66,240.00

**Special Instructions:**

CITY COUNCIL AWARD DATE: 6/24/2024. Contract for Acoustic Panel Replacement in the Senior Dining Room at the Troy Community Center in accordance with the specifications and completion date of ITB-COT 24-10. CERTIFICATE OF INSURANCE and ENDORSEMENTS shall be on file through contract completion.

**TERMS & CONDITIONS**

1. Purchases of Municipalities are exempt from State Sales and Federal Excise Taxes.
2. Prior to acceptance, vendor agrees to provide City with information under the Right-to-Know Law, P.A. 1986, No. 80, and fully comply with all terms and conditions of the Michigan Occupational Safety and Health Act, MCL 408.1001, et seq. including vendor shall provide City with an "MSDS". Vendor also agrees to be responsible for all required labeling.
3. In cases of emergency/disaster, the City can purchase up to six(6) times the order amount for a period of six(6) months at the price contained in the contract.
4. Purchase Orders are signed electronically based upon computer generated "on-line" authorized approvals. Authentic signatures are on file in the City of Troy Purchasing Department.

NOTICE: The City could put the vendor on notice that vendors will be held financially responsible for any claims or awards made against the City as a result of the vendor's action. If the City has to defend the initial lawsuit, the City will bring in the vendor as a co-defendant or sue the vendor, either as the result of settling a claim or the conclusion of the lawsuit.

I HEREBY CERTIFY THAT THIS ORDER IS PROPERLY AUTHORIZED AND APPROVED.

  
 \_\_\_\_\_

Opening Date: 06/13/2024  
 Date Reviewed: 06/13/2024

CITY OF TROY  
 BID TABULATION  
 ACOUSTIC WALL PANELS - SENIOR DINING ROOM

ITB-COT 24-10  
 Page 1 of 1

VENDOR NAME:	ISCG INC
CITY:	Royal Oak, MI

**PROPOSAL: TO PROVIDE AND INSTALL ACOUSTIC WALL PANELS IN THE SENIOR DINING ROOM LOCATED AT THE TROY COMMUNITY CENTER**

DESCRIPTION	QTY	UNIT COST	EXTENDED COST
<b>*Alternate items/quantity submitted for proposal</b>			
<b>PROPOSAL A:</b> Removal and disposal of existing acoustical panels and any necessary wall repairs. If necessary, dumpster to be provided by vendor.	1	\$3,750.00	\$3,750.00
<b>PROPOSAL B:</b> Horizontal Panels: Solid Wall/Ceiling Panels Standard Solid Panels: 12mm 12mm (ST) Peach- Solid Color 110"H 42"W Adhesive Backer Added *9mm 84"W X 47"H	57 *73	\$450.00	\$32,850.00
<b>PROPOSAL C:</b> Pillar Panels: Solid Wall/Ceiling Panels Standard Solid Panels: 12mm 12mm (ST) Peach- Solid Color 110"H 30"W Adhesive Backer Added * 9mm 72"W X 47"H	30 *27	\$345.00	\$9,315.00
<b>PROPOSAL D:</b> Attic Stock: Solid Wall/Ceiling Panels Standard Solid Panels: 12mm 12mm (ST) Peach- Solid Color 110"H 42"W Adhesive Backer Added *9mm 84"W X 47"H	3	\$450.00	\$1,350.00
<b>PROPOSAL E:</b> Attic Stock: Pillar Panels: Solid Wall/Ceiling Panels Standard Solid Panels: 12mm 12mm (ST) Peach- Solid Color 110"H 30"W Adhesive Backer Added * 9mm 72"W X 47"H	2	\$345.00	\$690.00
<b>PROPOSAL F:</b> Installation Labor and Materials	1	\$17,500.00	\$17,500.00
Freight		\$785.00	\$785.00
<b>PROPOSALS A - F TOTAL COST:</b>		<b>\$66,240.00</b>	

Descriptive Literature Provided:	Y or N	Y
Can Provide Samples:	Y or N	Y
Can Meet Completion Date:	Y or N	N - Product lead time 4-6 wks from time ordered. Does not include transit time.
Warranty:		3 YEARS Product and Installation
<b>Contact Information:</b> Hours of Operation:		7 a.m. - 4 p.m.
Contact Phone #:		313-663-6073
References:		Y
Can Provide Insurance:	Y or N	Y
Payment Terms:	Y or N	Y
Delivery Date:		TBD Based on Order Date
Exceptions:		We are using 9mm thick Mergeworks Echo/Decho solid panels. Sheet Sizes are 70 x 47 & 84 x 47. Once awarded we can elaborate on how they will be applied. Pillars will have horizontal seam w/ an overall height of 94". All colors available & attached to this bid are the same price.
Acknowledgement:	Y or N	Y
Signed Addendum:		Y
Forms:	Y or N	Y

Attest:

(\*Bid Opening conducted via a Zoom Meeting)

\_\_\_\_\_  
 Brian Goul  
 \_\_\_\_\_  
 Andrew Chambliss  
 \_\_\_\_\_  
 Nellie Bert  
 \_\_\_\_\_  
 Martinique Gates

\_\_\_\_\_  
 Emily Frontera  
 Purchasing Department



**CITY OF TROY  
BID PROPOSAL**

ITB-COT 24-10  
Page 1 of 6

The undersigned proposes to **PROVIDE AND INSTALL ACOUSTIC WALL PANELS IN THE SENIOR DINING ROOM LOCATED AT THE TROY COMMUNITY CENTER**, in accordance with the bid specifications attached hereto, which are to be considered an integral part of this proposal, at the following prices:

COMPANY NAME: ISCG INC

**PROPOSAL:** REMOVAL AND DISPOSAL OF OBSOLETE PANELS, AND INSTALLATION OF NEW CUSTOM ACOUSTIC WALL PANELS IN THE SENIOR DINING ROOM LOCATED AT THE TROY COMMUNITY CENTER. The undersigned, as bidder, declares that he/she has examined the specifications, including related documents. Being familiar with the conditions in the City of Troy and the type of work required, the bidder hereby proposes to furnish all labor, materials, equipment and supplies to provide services specified in the bid proposal documents, at the prices state below. The prices are to cover all expenses incurred in performing the work required.

Description:	QTY	Unit Cost	Extended Cost
<b>PROPOSAL A:</b> Removal and disposal of existing acoustical panels and any necessary wall repairs. If necessary, dumpster to be provided by vendor.	1	\$ <u>3,750</u>	\$ <u>3,750.00</u>
<b>PROPOSAL B:</b> Horizontal Panels: Solid Wall/Ceiling Panels Standard Solid Panels: 12mm 12mm (ST) Peach- Solid Color <sup>110"H 42"W</sup> Adhesive Backer Added <sub>84"X 47"H</sub>	<sup>73</sup> <del>67</del>	\$ <u>450.00</u>	\$ <u>32,850.00</u>
<b>PROPOSAL C:</b> Pillar Panels: Solid Wall/Ceiling Panels Standard Solid Panels: 12mm 12mm (ST) Peach- Solid Color <sup>110"H 30"W</sup> Adhesive Backer Added <sub>72"W X 47"H</sub>	<sup>27</sup> <del>30</del>	\$ <u>345.00</u>	\$ <u>9,315.00</u>
<b>PROPOSAL D:</b> Attic Stock: Solid Wall/Ceiling Panels Standard Solid Panels: 12mm 12mm (ST) Peach- Solid Color <sup>110"H 42"W</sup> Adhesive Backer Added <sub>84"W X 47"H</sub>	3	\$ <u>450.00</u>	\$ <u>1,350.00</u>
<b>PROPOSAL E:</b> Attic Stock: Pillar Panels: Solid Wall/Ceiling Panels Standard Solid Panels: 12mm 12mm (ST) Peach- Solid Color <sup>110"H</sup> <sub>30"W Adhesive Backer Added</sub> <sup>72"W X</sup>	2	\$ <u>345.00</u>	\$ <u>690.00</u>
<b>PROPOSAL F:</b> Installation Labor and Materials <sub>47"H</sub>	1		\$ <u>17,500.00</u>
<b>FREIGHT: \$785.00</b> Total Cost			\$ <u>66,240.00</u>

\*\*\* NO TAXES INCLUDED

**NOTE:** Pricing shall include all delivery costs, handling, and installation.

**UNIT PRICES:** Unit prices prevail. The City of Troy Purchasing Department will correct all mathematical errors.

**DESCRIPTIVE LITERATURE:**

Please attach descriptive or pertinent literature relevant to your company's bid proposal at the time of bid submission.

It is attached and marked ISCG TROY your identification DINING ROOM BID RESPONSE 1, WARRANTY 2, SPECS 3, FINISHES 4

**ADDITIONAL INFORMATION:**

For questions about the specifications, please contact **Dennis Trantham, Deputy Public Works Director**, at (248) 524-3503 between the hours of 8:00 AM and 4:30 PM, Monday through Friday.

**DELIVERY:**

All items will be FOB delivered inside, freight paid to the Troy Community Center, 3179 Livernois Rd., Troy, MI 48084, Attn: Dennis Trantham.

**APPROVED ALTERNATES:**

The City of Troy's Designated City Representative or his/her designee will review all items submitted for consideration as approved alternates. Their decision as to acceptability will be deemed in the City of Troy's best interest and will be final.

**SAMPLES:**

Actual samples of quoted product and material may be requested at the discretion of the City of Troy's designated representative. Samples will be provided at no cost to the City and will become the property of the City of Troy.

- Our Company can provide samples.
- Our Company cannot provide samples.

**MANDATORY SITE INSPECTION:**

All bidders are required to examine the Senior Dining Room to determine the amount of work to be done in accordance with the bid specifications by attending the **MANDATORY PRE-BID MEETING scheduled for Tuesday, June 4, 2024 at 1:00 pm** EDT at the Troy Community Center, 3179 Livernois Rd, Troy, MI. An opportunity to view and inspect the room and panels will be provided during the Pre-Bid Meeting. If Bidder does not attend the pre-bid meeting, the bidder will be considered non-responsive and no longer eligible for award.

**COMPLETION DATE:**

*It is preferred that all product be delivered and installed by **Friday, July 26, 2024**.* It will be the successful bidder's responsibility to work with Dennis Trantham, Deputy Public Works Director, to establish an acceptable delivery schedule. The City of Troy is the only party to this contract that may authorize amendment to this schedule.

- Our Company can meet this delivery schedule (**Friday, July 26, 2024**)
- Our Company cannot meet this delivery schedule but offers: **PRODUCT LEAD TIME APPROX 4-6 WEEKS FROM TIME ORDERED DOES NOT INCLUDE TRANSIT TIME**

**WARRANTY:**

State Warranty: 3 YEARS

**CONTACT INFORMATION:**

Hours of Operation: 7am - 4 P.M. Contact Phone # 313.663.6073

**CONTRACT FORMS:**

Bidders should complete, sign and include with their bid proposal the Legal Status of Bidder, Non-Collusion Affidavit, Certification regarding Debarment, the Certification regarding "Iran Linked Business" and the Familial Disclosure Forms.

**DOWN-PAYMENTS OR PREPAYMENTS:**

Any bid proposal submitted which requires a down-payment or prepayment prior to delivery and full acceptance of the item(s) as being in conformance with specifications will not be considered for award.

**AWARD:**

The evaluation and award of this bid shall be a combination of factors, including but not limited to: cost, professional competence, warranties, and the correlation of the proposal submitted to the needs of the City of Troy.

The City of Troy reserves the right to award this bid to the lowest responsible bidder meeting specifications to reject low bids which have major deviations from the specifications; to accept a higher bid which has only minor deviations, in whatever manner is deemed to be in the City of Troy's best interest.

**PURCHASE ORDER:**

After approval of the successful bidder by the Troy City Council, the purchase order issued from the City of Troy will create a bilateral contract between the parties and commit the successful bidder to perform the contract in accordance with specifications.

**LOCAL PREFERENCE:**

The City of Troy reserves the right to award a contract to a local business, one which pays City of Troy taxes (real and/or personal), if the bid of a local vendor is within 5% of the lowest responsive and responsible non-local bidder, then the local vendor is given one chance to match the low bid.

COMPANY NAME: ISCG INC

**SUBCONTRACTORS:**

The undersigned agrees to submit a list of proposed subcontractors, if applicable, for approval by the designated City representative within 72 hours after notification of being the low qualified bidder. It will be understood that this may occur prior to bid award, but the bidder's status will not be final until approved by the Troy City Council. All subcontracts will need to be approved by the designated City Representative.

**WORKMANSHIP AND INSPECTION:**

All work under the resulting purchase order shall be performed in a skillful and workmanlike manner. The City may, in writing, require the Contractor to remove any employee from work that the City deems incompetent or careless.

Further, the City may, from time to time, make inspections of the work performed under the purchase order. Any inspection by the City does not relieve the Contractor from any responsibility regarding defects or other failures to meet the contract requirements.

**MATERIAL AVAILABILITY:**

Bidders must accept responsibility for verification of material availability, production schedules, and other pertinent data prior to submission of bid and delivery time. It is the responsibility of the bidder to notify the City immediately if items specified are discontinued, replaced, or not available for an extended period of time.

**COMMERCIAL WARRANTY/MANUFACTURER'S RECOMMENDATIONS:**

The bidder agrees that supplies or services furnished shall be covered by the most favorable commercial warranties the bidder gives to any customer for such supplies or services. All warranty information and certificates shall be furnished and become the property of the City upon delivery of said items and all rights and remedies stated in the warranties must be honored by the contractor or his manufacturer.

All items are new manufacture unless otherwise specifically stated or called for in the bid.

All products offered must have passed the first line quality standards as set by the manufacturer and no seconds, blemished articles, or items containing defective workmanship are included.

Warranty shall also cover any problems due to manufacturing and/or installation of the acoustic panels. Entire installation shall meet or exceed manufacturer specifications.

**IMPORTANT:** All City of Troy purchases require a MATERIAL SAFETY DATA SHEET, where applicable, in compliance with the MIOSHA "Right to Know" Law. Please include a copy of any relevant MSDS at the time of bid submission.

**NOTE:** The City of Troy, at their discretion may require the bidder(s) to supply a Financial Report from an impartial Financial Credit Reporting Services before award of contract.

**REFERENCES**

Please list at least three (3) clients that have purchased similar product by your company.

COMPANY: U of M - CHRYSLER CENTER  
ADDRESS: 2121 Bonisteel Blvd, Ann Arbor, MI 48109  
CONTACT: JOHN MUCKER PHONE: 734.936.3501  
EMAIL: JOHNM@UMICH.EDU

COMPANY: RAVOS CONSTRUCTION  
ADDRESS: 104 E HIGHLAND RD, HIGHLAND MI 48256  
CONTACT: ROBERT JONES PHONE: 248.202.2837  
EMAIL: ROBERT@RAVOSINC.COM

COMPANY: PINNACLE CONTRACTORS  
ADDRESS: 111 GROVE PARK MI CLEMENS MI 48043  
CONTACT: MARLENE SEBAC PHONE: 586.401.4550  
EMAIL: MSEBAC@111PCI.COM

COMPANY NAME: ISCG INC

**INSURANCE:**

Insurance requirements shall be in accordance with the attached **SAMPLE INSURANCE CERTIFICATE** and **ENDORSEMENT**. The required Insurance Certificate and Endorsement must be submitted to the city within 5 days of the verbal/ electronic request after the bid award. The Insurance Certificate and Endorsement may be faxed to the Purchasing Office at (248) 619-7608, and is the only bid document accepted in this format.

The contractor, or any of their subcontractors, shall not commence work under this contract until they have obtained the insurance required, and shall keep such insurance in force during the entire life of this contract. All coverage shall be with insurance companies licensed and admitted to business in the State of Michigan and acceptable to the City of Troy. The requirements below should not be interpreted to limit the liability of the Contractor. All deductibles and self-insured retentions (SIR's) are the responsibility of the Contractor.

- We can meet the specified insurance requirements.
- We cannot meet the specified insurance requirements.
- We do not carry the specified limits but can obtain the additional insurance coverage of \$ \_\_\_\_\_, at the cost of \$ \_\_\_\_\_.  
**NOTE:** Please note the amendments on a sample insurance certificate and attach it to your bid proposal.
- Our proposal is reduced by \$ \_\_\_\_\_ if we lower the requirement to \$ \_\_\_\_\_.  
**NOTE:** Please note the amendments on a sample insurance certificate and attach it to your bid proposal.

**IMPORTANT:** A Certificate of Insurance on an ACORD Form showing present coverage as well as the required endorsements SHALL be attached to the proposal document at the time of submission of the proposal to the Office of the City Clerk.

**NOTE:** Failure on the part of any bidder to contact his/her insurance carrier to verify that the insurance carried by the bidder meets City of Troy specifications may result in this proposal being completed incorrectly.

**OTHER:** Sole proprietors must execute a certificate of exemption from Worker's Compensation requirements or provide proof of Worker's Compensation Insurance. All coverage shall be with insurance carriers licensed and admitted to do business in Michigan in accordance with all applicable statutes of the State of Michigan and acceptable to the City of Troy.

**INSURANCE VERIFICATION:**

A bidder shall complete the above portion, which details additional costs that may be incurred for specified coverage without purchasing the additional coverage prior to bid submission.

**WORKERS' COMPENSATION INSURANCE,** including Employers' Liability Coverage, in accordance with all applicable statutes of the State of Michigan.

**COMMERCIAL GENERAL LIABILITY INSURANCE** on an "Occurrence Basis" with limits of liability not less than \$1,000,000.00 per occurrence and aggregate. Coverage shall include the following extensions: (A) Contractual liability; (B) Products and Completed Operations; (C) Independent Contractors Coverage; (D) Broad Form General Liability Extensions or equivalent, if not already included; (E) Deletion of all Explosion, Collapse, and Underground (XCU) Exclusions, if applicable.

COMPANY NAME: ISCG INC.

**AUTOMOBILE LIABILITY**, including Michigan No-Fault Coverages, with limits of liability not less than \$1,000,000.00 per occurrence combined single limit for Bodily Injury, and Property Damage. Coverage shall include all owned vehicles, all non-owned vehicles, and all hired vehicles.

**ADDITIONAL INSURED:**

Commercial General Liability and Automobile Liability, as described in the attached SAMPLE shall include an Additional Insured Endorsement stating the following shall be ***Additional Insureds***: The City of Troy including all elected and appointed officials, all employees and volunteers, all boards, commissions, and/or authorities and council members, including employees and volunteers thereof. It is understood and agreed by naming the City of Troy as additional insured, coverage afforded is considered to be primary and any other insurance the City of Troy may have in effect shall be considered secondary and/or excess.

**CANCELLATION NOTICE:**

All policies, as described above, shall include an endorsement stating that it is understood and agreed that Thirty (30) days, Ten (10) days for non-payment of premium, Advance Written Notice of Cancellation, Non-Renewal, Reduction, and/or Material Change shall be mailed to:

City of Troy  
Purchasing Manager  
500 West Big Beaver  
Troy, MI 48084

**PROOF OF INSURANCE COVERAGE:**

The Contractor shall provide the City of Troy, at the time that the contracts are returned by him/her for execution, a Certificate of Insurance as well as the required endorsements. In lieu of required endorsements, if applicable, a copy of the policy sections where coverage is provided for additional insured and cancellation notice would be acceptable. Copies or certified copies of all policies mentioned above all shall be furnished, if so requested.

If any of the applicable coverages expire during the term of this contract, the Contractor shall deliver renewal certificates and endorsements to the City of Troy at least ten (10) days prior to the expiration date.

**LETTER VERIFICATION:**

The recommended bidder will be notified to submit a letter from the *insurance agent or carrier* that the insurance to be supplied will meet specifications. As an alternative, the recommended bidder may submit the certificate of insurance meeting specifications at this time at his/her option. ***The City must receive this letter or certificate within 5 business days after verbal / electronic notification has been delivered to the recommended bidder or the bidder will be considered non-responsive and the bid un-awardable.*** This process will occur before presentation of the award recommendation to the Troy City Council.

**FINAL INSURANCE CERTIFICATE SUBMISSION:**

After approval by Troy City Council, the City's Purchasing Manager will review the insurance certificates and endorsements to ensure all acceptable documents have been received and allow (5) business additional days after verbal / electronic notification to submit final insurance certificate(s) in accordance with specifications. The City of Troy reserves the right to WITHHOLD AND KEEP any bid surety for failure to comply. The company will be considered in default of contract and will be barred from doing business with the City of Troy for a minimum of three (3) years for failing to meet insurance requirements.

COMPANY NAME: ISCG INC.





**SIGNATURE PAGE**

**PRICES:**

Prices quoted shall remain firm for 60 days or bid award, whichever comes first, except the successful bidder(s) whose prices shall remain firm through delivery and final acceptance as operational in accordance with specifications.

SIGNATURE OF AUTHORIZED COMPANY REPRESENTATIVE: W. Kajtarovic

**NOTE:**

The undersigned has checked carefully the bid figures and understands that he/she shall be responsible for any error or omission in this bid offer and is in receipt of all addenda as issued.

TAX ID#: 38-2119920

COMPANY NAME: Interior Systems Contract Group, Inc (ISCG)

ADDRESS 612 N. Main St CITY Royal Oak STATE MI ZIP 48067

PHONE NUMBER 248.399.1600 FAX NUMBER 248.399.1601

REPRESENTATIVE'S NAME Nives Kajtarovic  
(Print)

SIGNATURE OF AUTHORIZED COMPANY REPRESENTATIVE \_\_\_\_\_

PAYMENT TERMS: 50% deposit, balance Net 30 WARRANTY: 3 years

E-MAIL: NKajtarovic@iscginc.com DELIVERY DATE: TBD BASED ON ORDER DATE

**EXCEPTIONS:**

Any exceptions, substitutions, deviations, etc., from the City specifications and this proposal must be stated below. The reason(s) for the exceptions, substitutions, and/or deviations are an integral part of this bid proposal offer:

We are using 9mm thick Mergeworks Echo/Decho solid panels. sheet sizes are 70" x 47" & 84" x 47". once awarded we can elaborate on how they will be applied. Pillars will have horizontal seam w/ an overall height of 94". All colors available & attached to this bid are the same price.

**ACKNOWLEDGEMENT:**

I, Nives Kajtarovic, certify that I have read the *Instructions to Bidders* (3 Pages) and that the bid proposal documents contained herein were obtained directly from the City's Purchasing Department or MITN Purchasing Group website, [www.bidnetdirect.com/city-of-troy-mi](http://www.bidnetdirect.com/city-of-troy-mi) and is an official copy of the Authorized Version.

SIGNATURE OF AUTHORIZED COMPANY REPRESENTATIVE: W. Kajtarovic

NOTE: The City of Troy, at their discretion, may require the bidder to supply a Financial Report from an impartial Financial Credit Reporting Service before award of contract at no cost to the City.

IMPORTANT: All City of Troy purchases require a **SAFETY DATA SHEET**, where applicable, in compliance with the MIOSHA "Right to Know" Law. Please include a copy of any relevant SDS at the time of bid submission.

U.S. CURRENCY: All figures quoted are to be in U.S. Funds.



June 4, 2024

**Addendum 1  
ITB-COT 24-10  
Acoustic Wall Panels – Senior Dining Room  
Page 1 of 2**

**To All Bidders:**

Please be advised that as a result of the Mandatory Pre-Bid Meeting conducted onsite at the Troy Community Center, 3179 Livernois Rd, Troy, MI 48083 on Tuesday, June 4, 2024 at 1:00 PM EDT - the Purchasing Department for the City of Troy authorized the following clarification(s) and or change(s) to the specifications for ITB-COT 24-10, Acoustic Wall Panels - Senior Dining Room. The clarification(s) and or change(s) will be considered an integral part of the original proposal document.

Items from the bid documents to be aware of and should be REVIEWED:

- **BID OPENING:** Thursday, June 13, 2024, at 10:00 AM EDT.
- All bidders are required to examine the site and verify field measurements to determine the amount of work to be done in accordance with the bid specifications by attending the **MANDATORY Pre-bid Meeting** that was scheduled for Tuesday, June 4, 2024 at 1:00 PM EDT LOCATED at the Troy Community Center Senior Dining Room. An opportunity to inspect and measure the site was provided during the Pre-bid Meeting.
- For *ADDITIONAL INFORMATION* or specific questions concerning this project, please contact Emily Frontera, Purchasing Manager at 248.524.3375.
- **COMPLETION SCHEDULE:** The designated City representative shall approve the work schedule prior to the start of the project. His/her decision as to acceptability shall be deemed in the City of Troy's best interest. The City of Troy is the only party to this contract that may authorize amendment of this schedule. The entire project must be complete by July 26, 2024.
- **CONTRACT FORMS:** Complete and sign all contract forms (Legal Status of Bidder, Non-Collusion Affidavit, Certification regarding Debarment, Certification regarding "Iran Linked Business", and the Familial Disclosure forms) and submit with your electronic bid proposal.
- **SIGNATURE PAGE:** Sign all three areas 1) Price Clause, 2) Company Info, 3) Acknowledgment.
- **EXCEPTIONS:** Any alternates, exceptions, substitutions, deviations to the bid proposal need to be stated in the including the reason in the Exceptions Section of the bid (Page 6 of 6).
- **INSURANCE:** If awarded - Insurance needs to be submitted to the City's Purchasing Manager, and approved before work can begin.
- **SPECIFICATIONS:** As detailed by room/area.

Attendance at the Pre-Bid Meeting was mandatory, everyone signed in. The following Companies were represented and in attendance:

Nives Kajtazovic	ISCG Inc
Billy Stapleton	Abstract Ceiling

Introduced:

Emily Frontera, Purchasing Manager  
 Brian Goul, Recreation Director  
 Joe Lagarde, Division Supervisor - Facilities  
 Lyndsey Ramsay, Recreation Supervisor



Clarifications were discussed as follows:

- Emily Frontera, Purchasing Manager gave a brief overview of the Instructions to Bidders and the requirements for bid submission.
  - The pre-bid meeting sign-in sheet is included with this Addendum (1 page)
- Joe Lagarde, Facilities Division Supervisor, discussed the preferred product requirements but alternates are encouraged to be submitted.

CLARIFICATIONS:

- Acoufelt is the preferred manufacturer, however, the City will review all items submitted for consideration as approved alternates. All alternate proposals not meeting bid specifications must be submitted as an exception.
- Requests for product samples may be made prior to award to determine final color and product quality
- All lighting and duct work will be removed by City prior to installation
- Room will be obstruction free, empty of all furnishings and available at the time work is to commence.
- Installer to remove and dispose old panels, space will be provided on-site for dumpster or trailer.
- It is the bidder's responsibility to field verify all measurements, wall applications and mounts.

I, the undersigned bidder, have read this Addendum 1 and have integrated the clarification(s) and or change(s) into the *Bid Proposal and Specifications* for **ITB-COT 24-10, ACOUSTIC WALL PANELS - SENIOR DINING ROOM**. All other items in the original bid proposal remain the same. This Addendum 1 should be included with the electronic bid submission, on or before **Thursday, June 13, 2024 at 1:00 AM EDT.**

COMPANY: ISCG INC

NAME OF AUTHORIZED COMPANY REPRESENTATIVE: Nives Kajtarovic

SIGNATURE: N. Kajtarovic

ADDRESS: 612 N. Main St  
Royal Oak, MI 48067

DATE: 6/11/24





## Legal Status of Bidder:

The Bidder shall fill out the appropriate form and strike out the other two:

---

A corporation duly organized and doing business under the laws of the State of Michigan for whom Nives Kajtzovic, bearing the office title of workplace consultant, whose signature is affixed to this proposal, is duly authorized to execute contracts.

---

A partnership, all members of which, with addresses, is:

<hr/> <hr/> <hr/> <hr/> <hr/> <hr/> <hr/>	<hr/> <hr/> <hr/> <hr/> <hr/> <hr/> <hr/>
---	---

---

AN INDIVIDUAL, WHOSE SIGNATURE IS AFFIXED TO THE PROPOSAL:

<hr/>	<hr/>
-------	-------



CITY OF TROY  
OAKLAND COUNTY, MICHIGAN  
NON-COLLUSION AFFIDAVIT

TO WHOM IT MAY CONCERN:

Nives Kajtazovic, being duly sworn deposed, says that he/she  
(Print Full Name)

is Workplace Consultant. The party making the foregoing proposal or bid,  
(State Official Capacity in Firm)

that such bid is genuine and not collusion or sham; that said bidder has not colluded, conspired, connived, or agree, directly or indirectly, with any bidder or person, to put in a sham bid or to refrain from bidding and has not in any manner directly or indirectly sought by agreement or collusion, or communication or conference, with any person to fix the bid price or affiant or any other bidder, or to fix any overhead, profit, or cost element of said bid price, or that of any other bidder, or to secure the advantage against the City of Troy or any person interested in the proposed contract; and that all statements contained in said proposal or bid are true.

N. Kajtazovic

SIGNATURE OF PERSON SUBMITTING BID

Angelica Viviano Noliff

NOTARY'S SIGNATURE

Subscribed and sworn to before me this 11 day of June, 2024

in and for Macomb County.

My commission expires:

9/29/27

ANGELICA VIVIANO NOLIFF  
Notary Public, State of Michigan  
County of Macomb  
My Commission Expires Sep. 29, 2027  
Acting in the County of Oakland



**CERTIFICATION REGARDING  
DEBARMENT, SUSPENSION, AND OTHER RESPONSIBILITY MATTERS**

The prospective participant certifies, to the best of its knowledge and belief, that it and its principals:

1. Are not presently debarred, suspended, proposed for debarment, declared ineligible, or voluntarily excluded from participation in transactions under any non-procurement programs by any federal, state or local agency.
2. Have not, within the three year period preceding, had one or more public transactions (federal, state, or local) terminated for cause or default; and
3. Are not presently indicted or otherwise criminally or civilly charged by a government entity (federal, state, or local) and have not, within the three year period preceding the proposal, been convicted of or had a civil judgment rendered against it:
  - a. For the commission of fraud or a criminal offense in connection with obtaining, attempting to obtain, or performing a public transaction (federal, state, or local), or a procurement contract under such a public transaction;
  - b. For the violation of federal, or state antitrust statutes, including those proscribing price fixing between competitors, the allocation of customers between competitors, or bid rigging; or
  - c. For the commission of embezzlement, theft, forgery, bribery, falsification or destruction of records, making false statements, or receiving stolen property.

I understand that a false statement on this certification may be grounds for the rejection of this proposal or the termination of the award. In addition, the general grant of this authority exists within the City's Charter, Chapter 12, Section 12.2- Contracts.

*I am able to certify to the above statements.*

Interior Systems Contract Group, Inc.

Name of Agency/Company/Firm (Please Print)

Nives Kajtazovic

Name and title of authorized representative (Please Print)

N. Kajtazovic

Signature of authorized representative

6/11/24

Date

*I am unable to certify to the above statements. Attached is my explanation.*



**VENDOR CERTIFICATION  
THAT IT IS NOT AN  
"IRAN LINKED BUSINESS"**

Pursuant to Michigan law, (the Iran Economic Sanctions Act, 2012 PA 517, MCL 129.311 et seq.), before accepting any bid or proposal, or entering into any contract for goods or services with any prospective Vendor, the Vendor must first certify that it is not an "IRAN LINKED BUSINESS", as defined by law.

Vendor	
Legal Name	Interior Systems Contract Group, Inc .
Street Address	4612 N. Main St .
City	Royal Oak
State, Zip	MI , 48067
Corporate I.D. Number/State	Michigan
Taxpayer I.D. #	38-2119920

The undersigned, with: 1.)full knowledge of all of Vendors business activities, 2.)full knowledge of the requirements and possible penalties under the law MCL 129.311 et seq. and 3.) the full and complete authority to make this certification on behalf of the Vendor, by his/her signature below, certifies that: the Vendor is NOT an "IRAN LINKED BUSINESS" as require by MCL 129.311 et seq., and as such that Vendor is legally eligible to submit a bid and be considered for a possible contract to supply goods and/or services to the City of Troy.

Signature of Vendor's Authorized Agent: W. Kajtazovic

Printed Name of Vendor's Authorized Agent: Nives Kajtazovic

Witness Signature: Angelica Nolf

Printed Name of Witness: Angelica Nolf





**Proposer's Sworn and Notarized Familial Disclosure**  
*(to be provided by the Proposer)*

The undersigned, the owner or authorized officer of ISCG (the "Proposer"), pursuant to the familial disclosure requirement provided in the Request for Proposal, hereby represent and warrant, except as provided below, that no familial relationships exist between the owner(s) or any employees of ISCG and any member of the City of Troy City Council or City of Troy management.

**List any Familial Relationships:**

none

BIDDER: ISCG

By: W. Hajtovic

Its: Workplace Consultant

STATE OF MICHIGAN

) ss.

COUNTY OF Macomb)

This instrument was acknowledged before me on the 11 day of June, 2024, by

Angelica Viviano Nolf

ANGELICA VIVIANO NOLFF  
Notary Public, State of Michigan  
County of Macomb  
My Commission Expires Sep, 29, 2027  
Acting In the County of Cakland

# MATERIALS & FINISHES

## ECHOSCAPE™ 3/8" (9MM)

CIRLED OPTIONS ARE FORE ECHOSPACE WALL PANEL ALL COLORS ARE SAME PRICE

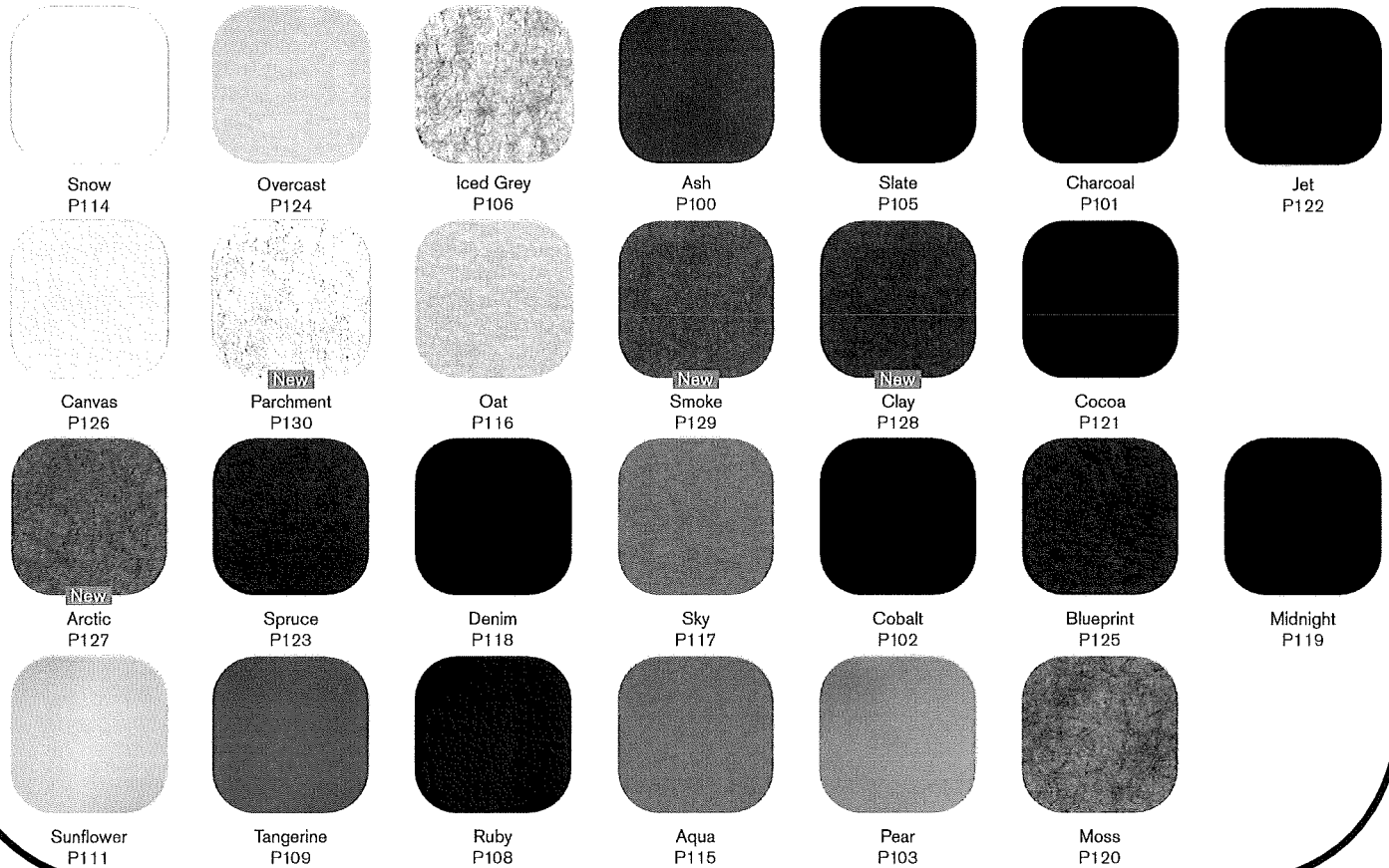

## ECHOSCAPE® WOODGRAIN PATTERNS 3/8" (9MM)

Woodgrain pattern runs horizontal

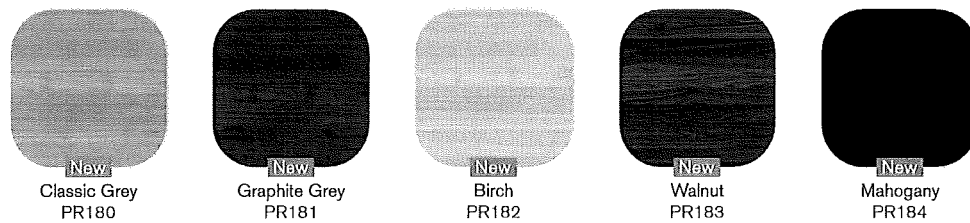

## ECHOSCAPE™ 3/4" (18MM)

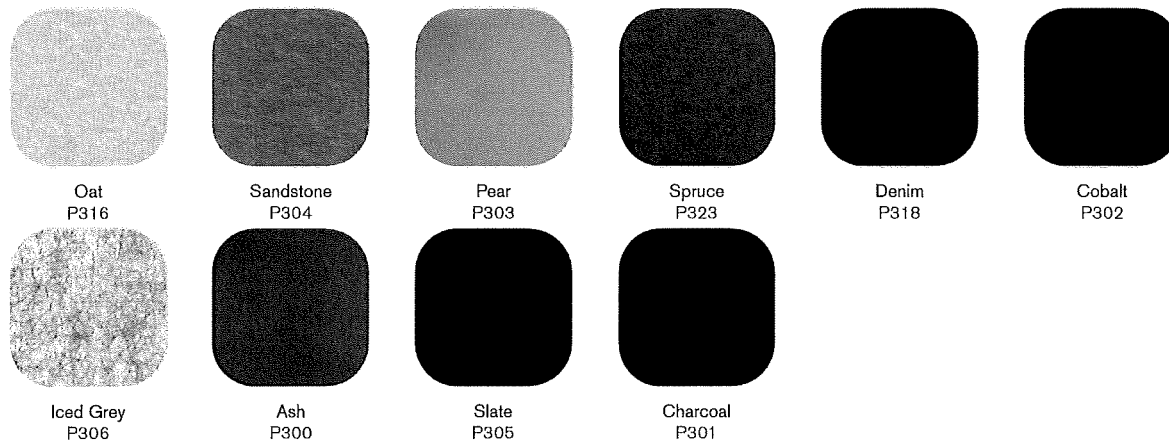

# FABRICS 200 SERIES

## FELTRO | NEW NOVEMBER 2023



Slate  
F232

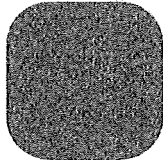

Steel  
F237

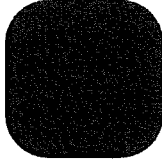

Shadow  
F241

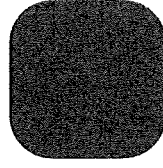

Baltic  
F238

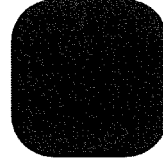

Dusk  
F242

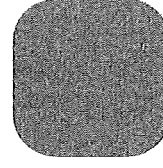

Birch  
F233

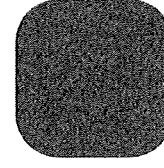

Twig  
F235

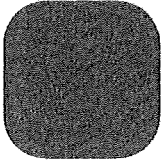

Spa  
F239

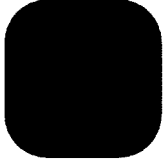

Ink  
F243

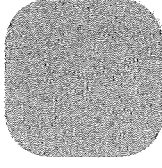

Sand  
F234

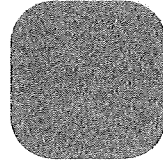

Celadine  
F236

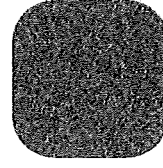

Sprout  
F240

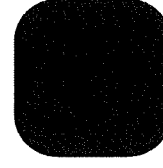

Cayenne  
F244

## DEKA | NEW NOVEMBER 2023

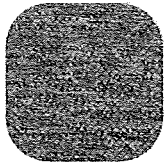

Moon  
F245



Mercury  
F252

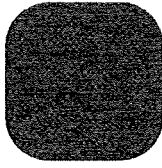

Pewter  
F256

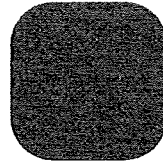

Refresh  
F247

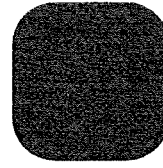

Rain  
F249

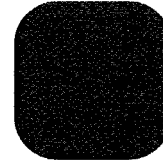

Nordic  
F253

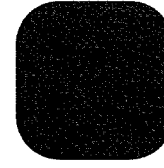

Charcoal  
F257

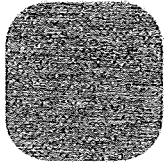

Peridot  
F250

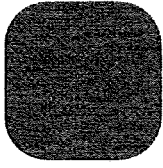

Copper  
F254



Bisque  
F251

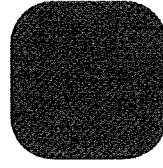

Driftwood  
F255

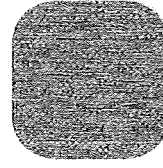

Pumice  
F246



Sage  
F248

## INFINITY

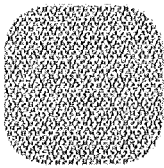

Dove  
F223

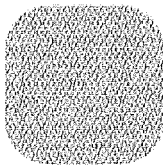

Barley  
F210

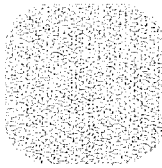

Stucco  
F221

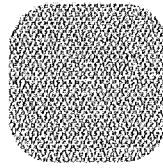

Aluminum  
F222

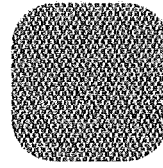

Gull  
F230

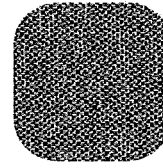

Pewter  
F231

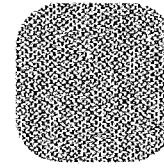

Aster  
F219

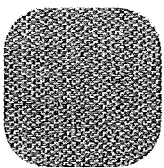

Rinse  
F214

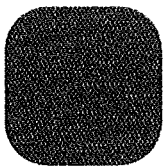

Capri  
F218

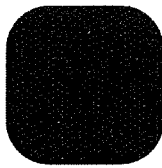

Beyond  
F220

# FABRICS 100 SERIES

## ORIGIN

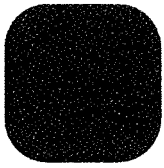

Euro  
F102

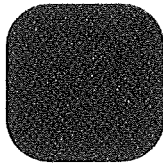

Poppy  
F104

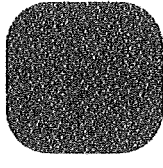

Arundel  
F112

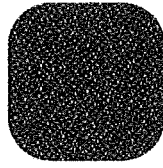

Stately  
F113

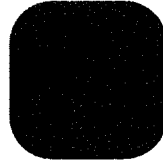

Basalt  
F122

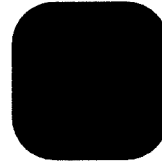

Jet  
F123

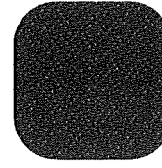

Iron  
F121

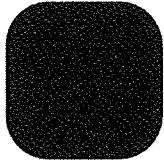

Steel  
F120

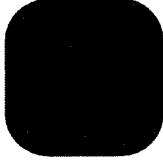

Sapphire  
F114

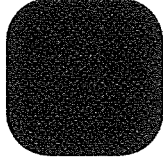

Sodalite  
F108

## LAMINATES

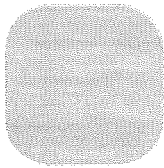

Phantom Ecru  
L100

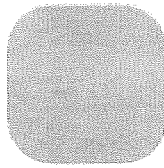

Fusion Maple  
L120

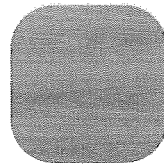

New Age Oak  
L102

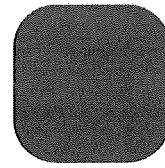

Huntington Maple  
L118

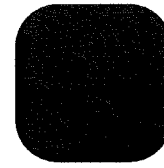

Windswept Bronze  
L103

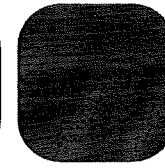

Black Walnut  
L104

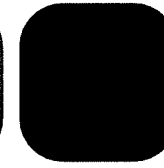

Cafelle  
L107

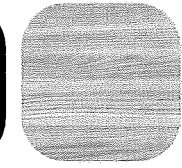

Grey Elm  
L121



Bleached Legno  
L105

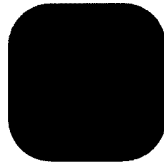

Asian Night  
L119

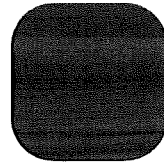

Smokey Brown Pear  
L106

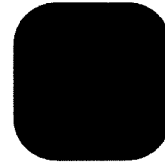

Blackened Legno  
L108

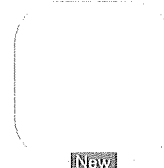

**New**  
Frosty White  
L124

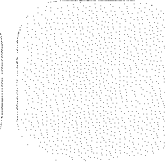

Folkstone  
L110

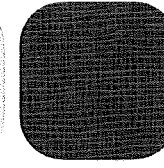

Citadel Warp  
L111

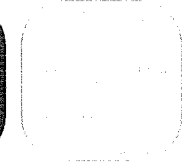

White Drops  
L113

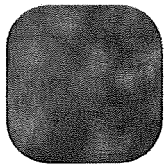

Woolamai Brush  
L114

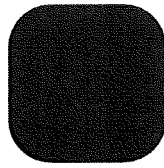

Blue Agave  
L115

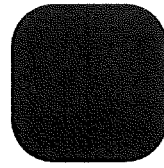

Hollyberry  
L116

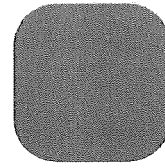

Clementine  
L117

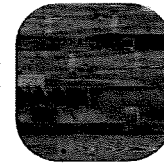

Antique Cognac Pine  
L300

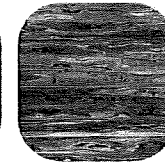

Recon Olive  
L301

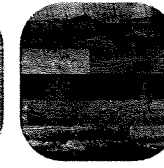

Repurposed Oak Plank  
L302

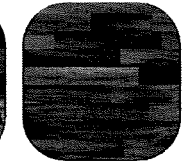

Small Planked  
L303



Mocha Olive  
L304

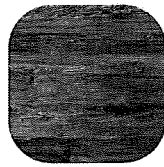

Lost Pine  
L305



Antique Barrel  
L306

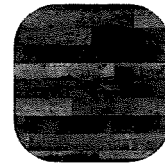

Reclaimed Oak Plank  
L307

## FROSTED ACRYLIC

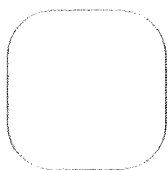

Frosted Acrylic  
FRO

## LUMICOR 100 SERIES (LM1\_)

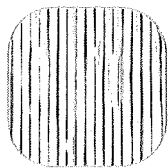

Cirrus Ivory  
LM101

Grain Direction  
Horizontal - Villa Wall™  
Vertical - All products  
except Villa Wall™



White Fiberoptic  
LM102

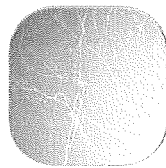

Vena  
LM103

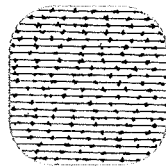

Fuse Garnet  
LM104

Grain Direction  
Horizontal - All products  
except Villa Wall™  
Vertical - Villa Wall™

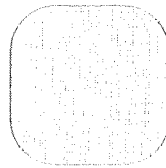

Oyster Linen  
LM105

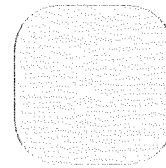

Rhythm  
LM106

Grain Direction  
Horizontal - All products  
except Villa Wall™  
Vertical - Villa Wall™

## LUMICOR 200 SERIES (LM2\_)

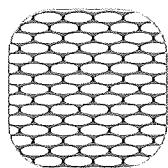

Ovalsque Print  
LM201

Grain Direction  
Horizontal - All products  
except Villa Wall™  
Vertical - Villa Wall™

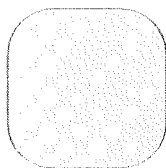

Helix  
LM202

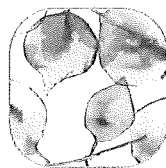

Walden Dusk  
LM203

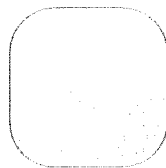

Kauri  
LM204



Koori  
LM205

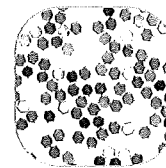

Take II  
LM206

Note  
Only Available for  
Enclave®, Enclave®  
Privacy Plus and  
Stackers™

## DRY ERASE SURFACES

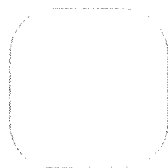

TruBrite™ Whiteboard  
WB

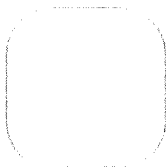

Clear Glass Board  
GCL

## FRAMES

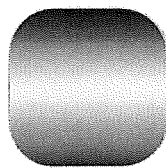

Satin Aluminum  
AA

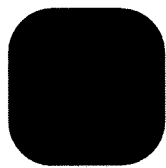

Black  
BK

## TABLE BASE

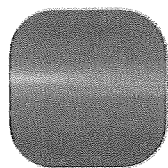

Silver  
S

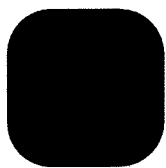

Black  
BK



White  
W

## EDGE BAND

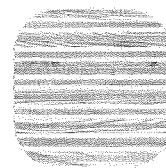

Multi-plywood  
P

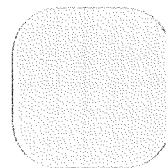

Silver  
S

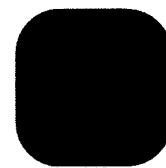

Black  
BK

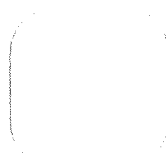

White  
W

# ECHODECO® WALL PANELS

Price Effective - January 1, 2024



## SET THE TONE IN YOUR WORKSPACE

Improve office acoustics while creating an inspiring environment with EchoDeco® Wall Panel cutout designs. An attractive decorative solution that absorbs distracting noise. Easy to install, EchoDeco® Wall Panels can be hung from the ceiling or attached directly to a wall. EchoDeco® designs can be customized to match any décor, style or brand.

- Panel designs are available with 1 layer to 3 layers:
  - Layer 1 is the cutout design panel, choose from over 30 designs or send us your custom design
  - Layer 2 is a solid panel adhered to the back of the design, adding color and acoustic value
  - Layer 3 adds a second cutout design panel to the back of the solid panel, creating a double-sided design

- EchoDeco® panels in 3/8" (9mm) material thickness are available in 26 colors and have an NRC rating of 0.85
- EchoDeco® panels in 3/4" (18mm) material thickness are available in 10 colors and have an NRC rating of 0.9. This material can only be used on design cutout panel layer 1, no other layers can be added to the design panel
- EchoScape™ is sustainable, VOC-free, and is 100% recyclable
- Several ceiling hanging options available
- Several wall hanging options available
- Made in the USA
- Custom designs available

How to build your SKU:

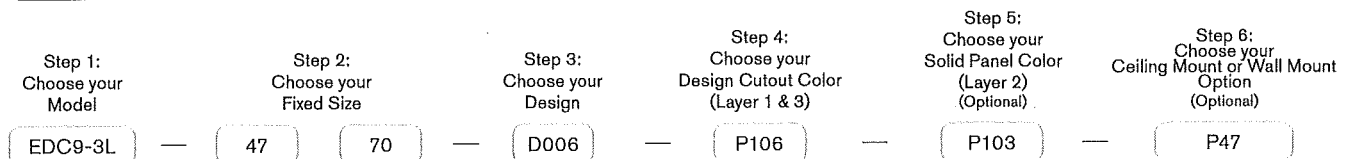

## ECHODECO® ACOUSTIC WALL PANELS

Model	Fixed Sizes	Design	Design Cutout Color	Backer Color (Layer 2) (Optional)	Ceiling Mount Options G= ACT Grid Mount* P= Permanent Mount L= Loop Mount	Wall Mounting Options
EDC9-1L	EchoDeco® 3/8" (9mm) Design panel, single Layer 23.5" w x 47" h	D0_ See pg. 6-20 for design options	P1_ EchoScape® 3/8" (9mm) - Layer 1 & Layer 3 only	P1_ EchoScape® 3/8" (9mm) - Layer 2 only	G, P, or L23.5 Metal channel - 23.5" width ceiling mount	SM3 Strap Mount SSO Silver Standoffs
EDC18-1L	EchoDeco® 3/4" (18mm) Design panel, single Layer 47" w x 47" h				G, P, or L47 Metal channel - 47" width ceiling mount	BSO Black Standoffs W.R_ Adhesive
EDC9-2L	EchoDeco® 3/8" (9mm) Design panel with solid back panel, 2 Layers 70" w x 47" h		P3_ EchoScape® 3/4" (18mm) - Layer 1 only		G, P, or L70 Metal channel - 70" width ceiling mount	Removable Mount
EDC9-3L	EchoDeco® 3/8" (9mm) 2 Design panels separated by solid panel, 3 Layers 84" w x 47" h				G, P, or L94 Metal channel - 94" width ceiling mount	

\*Compatible with standard 1" (15/16") ceiling grids

**ECHODECO® WALL PANELS  
D000 SOLID DESIGN**

Width	Height	9mm Solid Panel (List Price)	18mm Solid Panel (List Price)	Ceiling Mount Options					Wall Mounting Options							Acoustic Sq. Ft.	9mm Weight (lbs)	18mm Weight (lbs)			
				Metal Channel Hanging Kit Ceiling Attachment Options G= ACT Grid P= Permanent L= Loop					Strap Mounts	Standoff Mount (S or B)	Adhesive Removable Mount WR8 = 8 Sets WR16 = 16 Sets WR24 = 24 Sets WR28 = 28 Sets WR32 = 32 Sets										
				G, P, OR L 23.5	G, P, OR L 47	G, P, OR L 70	G, P, OR L 84	G, P, OR L 94			SM3	SO4	SO6	WR8	WR16				WR24	WR28	WR32
23.5"	47"	\$280	\$410	+\$130	N/A	N/A	N/A	N/A				+\$60	N/A	+\$25	N/A	N/A	N/A	N/A	8	4	6
47"	23.5"	\$280	\$410	N/A	+\$190	N/A	N/A	N/A				+\$60	N/A	+\$25	N/A	N/A	N/A	N/A	8	4	6
47"	47"	\$440	\$660	N/A	+\$190	N/A	N/A	N/A				+\$60	N/A	N/A	+\$50	N/A	N/A	N/A	15	8	13
47"	70"	\$625	\$1,065	N/A	+\$190	N/A	N/A	N/A				N/A	+\$90	N/A	N/A	+\$75	N/A	N/A	23	11	18
70"	47"	\$625	\$1,065	N/A	N/A	+\$260	N/A	N/A	+\$35			N/A	+\$90	N/A	N/A	+\$75	N/A	N/A	23	11	18
47"	84"	\$820	\$1,210	N/A	+\$190	N/A	N/A	N/A				N/A	+\$90	N/A	N/A	N/A	+\$88	N/A	27	13	21
84"	47"	\$820	\$1,210	N/A	N/A	N/A	+\$280	N/A				N/A	+\$90	N/A	N/A	N/A	+\$88	N/A	27	13	21
47"	94"	\$865	\$1,275	N/A	+\$190	N/A	N/A	N/A				N/A	+\$90	N/A	N/A	N/A	N/A	+\$100	31	15	23
94"	47"	\$865	\$1,275	N/A	N/A	N/A	N/A	+\$300				N/A	+\$90	N/A	N/A	N/A	N/A	+\$100	31	15	23

**ECHODECO®  
D000 - SOLID**

- D000 - SOLID  
SIZES**
- 23.5"W x 47"H
  - 47"W x 23.5"H
  - 47"W x 47"H
  - 47"W x 70"H
  - 70"W x 47"H
  - 47"W x 84"H
  - 84"W x 47"W
  - 47"W x 94"H
  - 94"W x 47"H

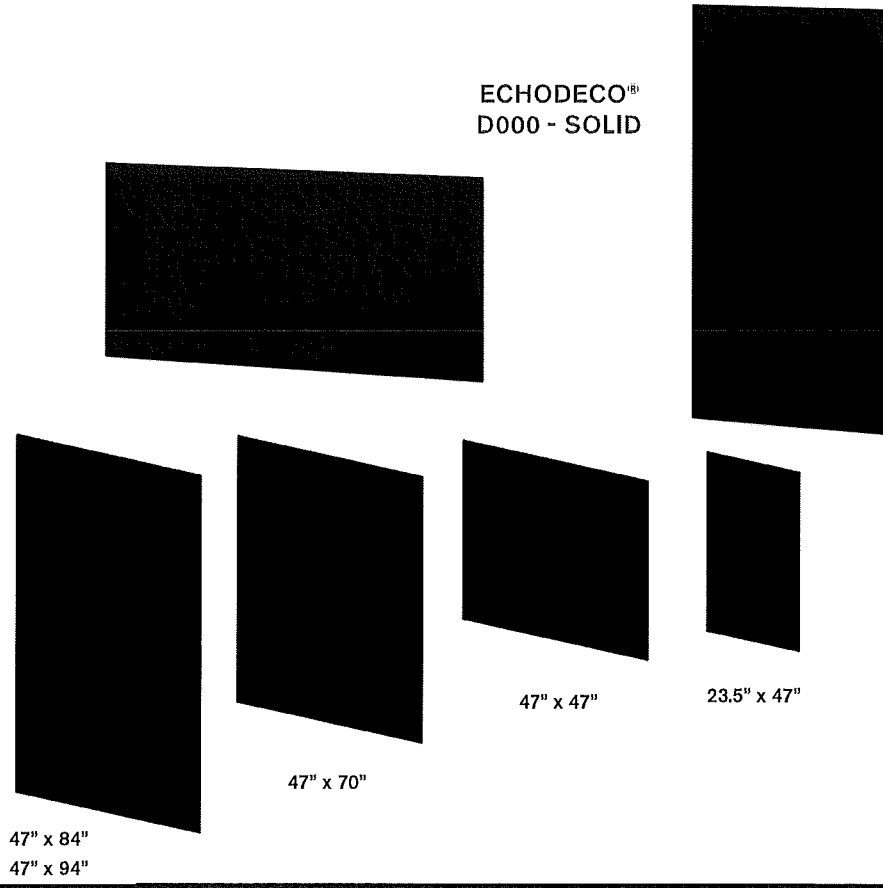

NOTE: All pricing in USD

# ECHODECO® WALL PANELS

## ECHODECO® WALL PANELS - 1 LAYER PANEL EDC9-1L OR EDC18-1L (See pg. 6-19 for design options)

Width	Height	9mm 1 Layer Cutout Design Panel (List Price)	18mm 1 Layer Cutout Design Panel (List Price)	Ceiling Mount Options					Wall Mounting Options							Acoustic Sq. Ft.	9mm Weight (lbs)	18mm Weight (lbs)	
				Metal Channel Hanging Kit Ceiling Attachment Options G= ACT Grid P= Permanent L= Loop					Strap Mounts	Standoff Mount (S or B)			Adhesive Removable Mount WR8 = 8 Sets WR16 = 16 Sets WR24 = 24 Sets WR28 = 28 Sets WR32 = 32 Sets						
				G, P, OR L 23.5	G, P, OR L 47	G, P, OR L 70	G, P, OR L 84	G, P, OR L 94		SM3	SO4	SO6	WR8	WR16	WR24	WR28	WR32		
23.5"	47"	\$313	\$456	+\$130	N/A	N/A	N/A	N/A		+\$60	N/A	+\$25	N/A	N/A	N/A	N/A	8	4	6
47"	23.5"	\$313	\$456	N/A	+\$190	N/A	N/A	N/A		+\$60	N/A	+\$25	N/A	N/A	N/A	N/A	8	4	6
47"	47"	\$487	\$736	N/A	+\$190	N/A	N/A	N/A		+\$60	N/A	N/A	+\$50	N/A	N/A	N/A	15	8	13
47"	70"	\$697	\$1,185	N/A	+\$190	N/A	N/A	N/A		N/A	+\$90	N/A	N/A	+\$75	N/A	N/A	23	11	18
70"	47"	\$697	\$1,185	N/A	N/A	+\$260	N/A	N/A	+\$35	N/A	+\$90	N/A	N/A	+\$75	N/A	N/A	23	11	18
47"	84"	\$912	\$1,345	N/A	+\$190	N/A	N/A	N/A		N/A	+\$90	N/A	N/A	N/A	+\$88	N/A	27	13	21
84"	47"	\$912	\$1,345	N/A	N/A	N/A	+\$280	N/A		N/A	+\$90	N/A	N/A	N/A	+\$88	N/A	27	13	21
47"	94"	\$960	\$1,416	N/A	+\$190	N/A	N/A	N/A		N/A	+\$90	N/A	N/A	N/A	N/A	+\$100	31	15	23
94"	47"	\$960	\$1,416	N/A	N/A	N/A	N/A	+\$300		N/A	+\$90	N/A	N/A	N/A	N/A	+\$100	31	15	23

LINE DRAWING  
1 LAYER PANEL

LAYER 1  
DESIGN PANEL

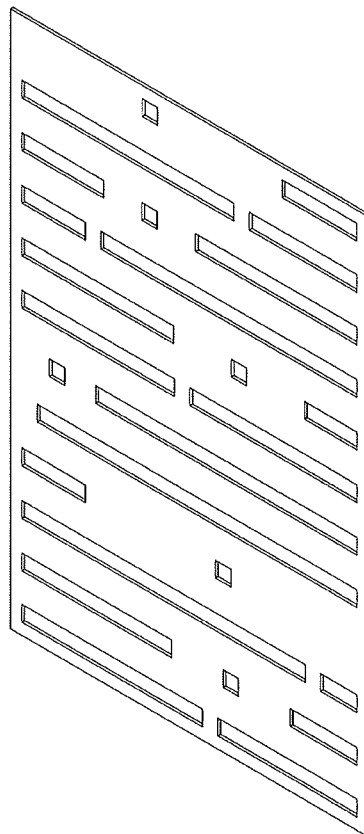

NOTE: All pricing in USD



# ECHODECO® WALL PANELS

## ECHODECO® WALL PANELS - 2 LAYER PANEL EDC9-2L

(See pg. 6-19 for design options)

Width	Height	2 Layer Panel (List Price) Layer 1 - Design Layer 2 - Solid Panel	Ceiling Mount Options					Wall Mounting Options									Acoustic Sq. Ft.	Weight (lbs)
			Metal Channel Hanging Kit Ceiling Attachment Options G= ACT Grid P= Permanent L= Loop					Strap Mounts	Standoff Mount (S or B)			Adhesive Removable Mount WR8 = 8 Sets WR16 = 16 Sets WR24 = 24 Sets WR28 = 28 Sets WR32 = 32 Sets						
			G, P, OR L 23.5	G, P, OR L 47	G, P, OR L 70	G, P, OR L 84	G, P, OR L 94		SM3	SO4	SO6	WR8	WR16	WR24	WR28	WR32		
23.5"	47"	\$594	+\$130	N/A	N/A	N/A	N/A		+\$60	N/A	+\$25	N/A	N/A	N/A	N/A	8	7	
47"	23.5"	\$594	N/A	+\$190	N/A	N/A	N/A		+\$60	N/A	+\$25	N/A	N/A	N/A	N/A	8	7	
47"	47"	\$918	N/A	+\$190	N/A	N/A	N/A		+\$60	N/A	N/A	+\$50	N/A	N/A	N/A	15	14	
47"	70"	\$1,319	N/A	+\$190	N/A	N/A	N/A		N/A	+\$90	N/A	N/A	+\$75	N/A	N/A	23	20	
70"	47"	\$1,319	N/A	N/A	+\$260	N/A	N/A	+\$35	N/A	+\$90	N/A	N/A	+\$75	N/A	N/A	23	20	
47"	84"	\$1,727	N/A	+\$190	N/A	N/A	N/A		N/A	+\$90	N/A	N/A	N/A	+\$88	N/A	27	24	
84"	47"	\$1,727	N/A	N/A	N/A	+\$280	N/A		N/A	+\$90	N/A	N/A	N/A	+\$88	N/A	27	24	
47"	94"	\$1,818	N/A	+\$190	N/A	N/A	N/A		N/A	+\$90	N/A	N/A	N/A	N/A	+\$100	31	27	
94"	47"	\$1,818	N/A	N/A	N/A	N/A	+\$300		N/A	+\$90	N/A	N/A	N/A	N/A	+\$100	31	27	

LINE DRAWING  
2 LAYER PANEL

LAYER 1  
DESIGN PANEL

LAYER 2  
SOLID PANEL

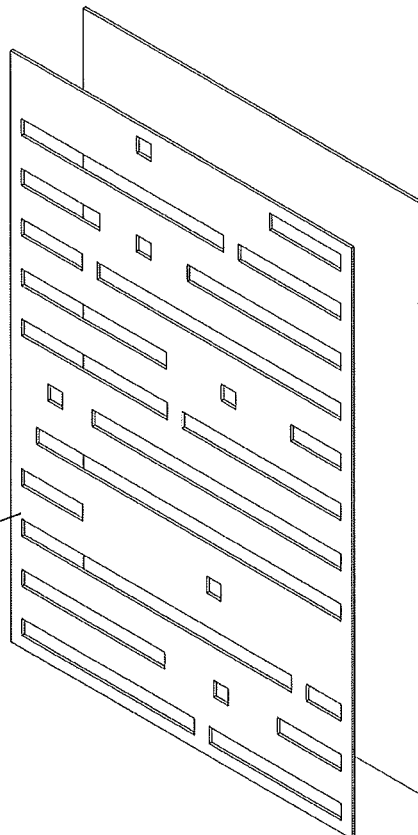

NOTE: All pricing in USD

**ECHODECO® WALL PANELS - 3 LAYER PANEL**  
**EDC9-3L**

(See pg. 6-19 for design options)

Width	Height	3 Layer Panel (List Price) <small>Layer 1 - Design Layer 2 - Solid Panel Layer 3 - Design</small>	Ceiling Mount Options					Acoustic Sq. Ft.	Weight (lbs)
			G, P, OR L 23.5	G, P, OR L 47	G, P, OR L 70	G, P, OR L 84	G, P, OR L 94		
23.5"	47"	\$781	+\$130	N/A	N/A	N/A	N/A	8	9
47"	23.5"	\$781	N/A	+\$190	N/A	N/A	N/A	8	18
47"	47"	\$1,219	N/A	+\$190	N/A	N/A	N/A	15	18
47"	70"	\$1,740	N/A	+\$190	N/A	N/A	N/A	23	27
70"	47"	\$1,740	N/A	N/A	+\$260	N/A	N/A	23	27
47"	84"	\$2,279	N/A	+\$190	N/A	N/A	N/A	27	33
84"	47"	\$2,279	N/A	N/A	N/A	+\$280	N/A	27	33
47"	94"	\$2,401	N/A	+\$190	N/A	N/A	N/A	31	36
94"	47"	\$2,401	N/A	N/A	N/A	N/A	+\$300	31	36

**LINE DRAWING**  
**3 LAYER PANEL**

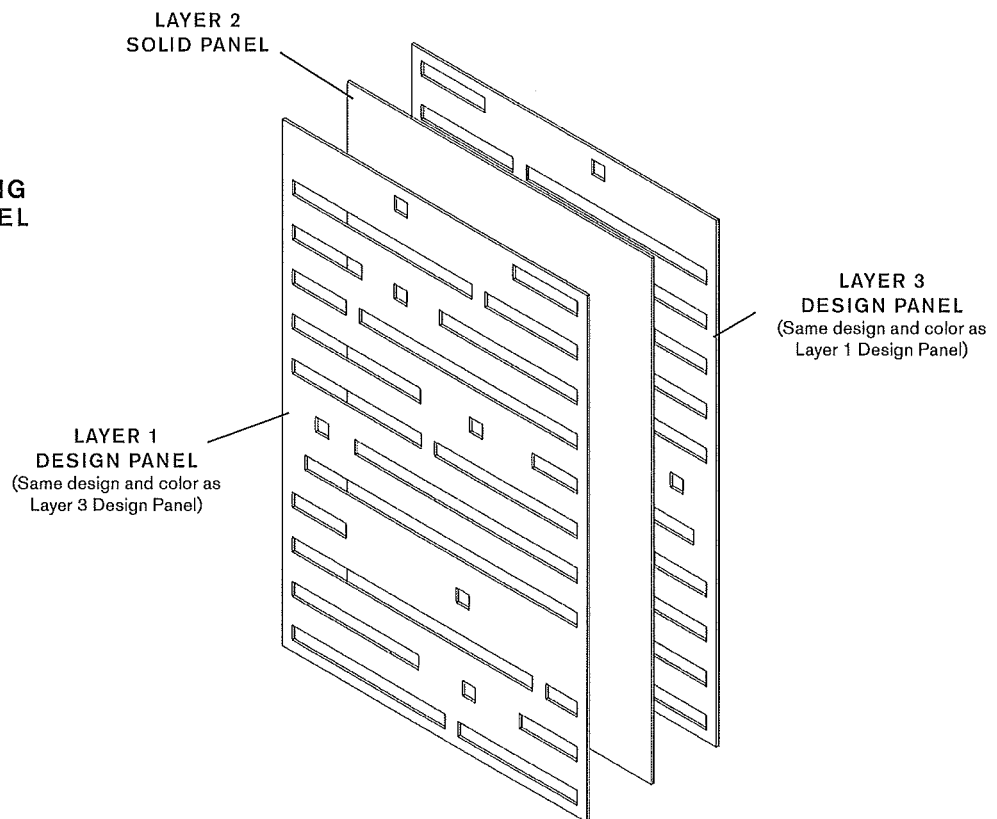

NOTE: All pricing in USD

ECHODECO®  
D001 - FOLIAGE

**D001 - FOLIAGE  
SIZES**

- 23.5"W x 47"H
- 47"W x 23.5"H
- 47"W x 47"H
- 47"W x 70"H
- 70"W x 47"H
- 47"W x 84"H
- 84"W x 47"H
- 47"W x 94"H
- 94"W x 47"H

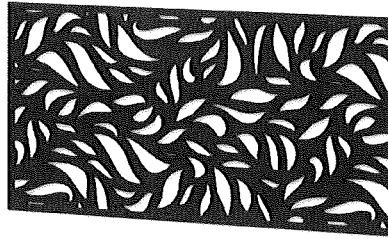

47" x 94"

47" x 84"

47" x 70"

47" x 47"

23.5" x 47"

ECHODECO®  
D002 - FIZZY

**D002 - FIZZY  
SIZES**

- 23.5"W x 47"H
- 47"W x 23.5"H
- 47"W x 47"H
- 47"W x 70"H
- 70"W x 47"H
- 47"W x 84"H
- 84"W x 47"H
- 47"W x 94"H
- 94"W x 47"H

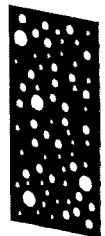
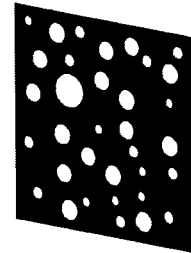
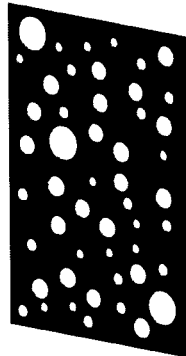
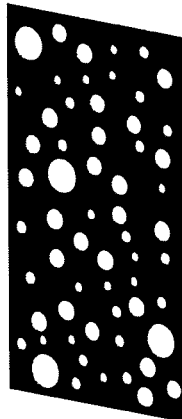
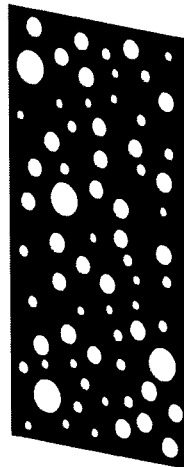
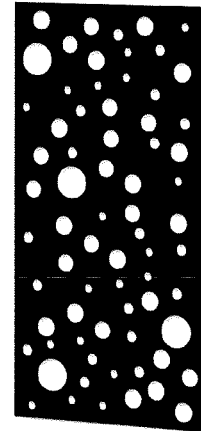
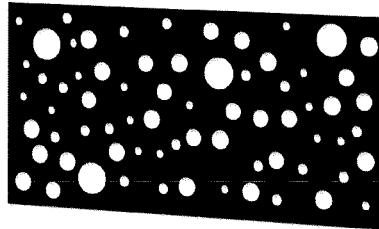

47" x 94"

47" x 84"

47" x 70"

47" x 47"

23.5" x 47"

# ECHODECO® WALL PANEL DESIGNS

## ECHODECO® D003 - WEB

### D003 - WEB SIZES

- 23.5"W x 47"H
- 47"W x 23.5"H
- 47"W x 47"H
- 47"W x 70"H
- 70"W x 47"H
- 47"W x 84"H
- 84"W x 47"H
- 47"W x 94"H
- 94"W x 47"H

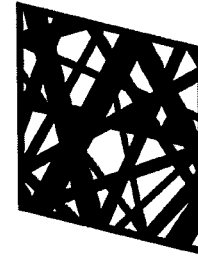
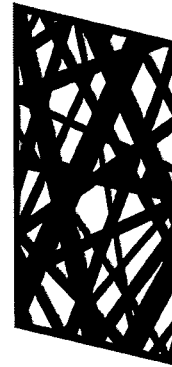
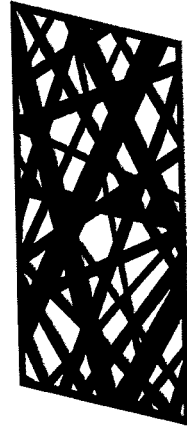
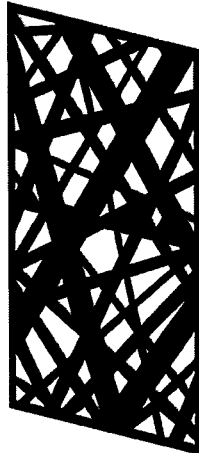
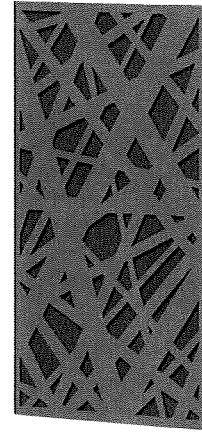
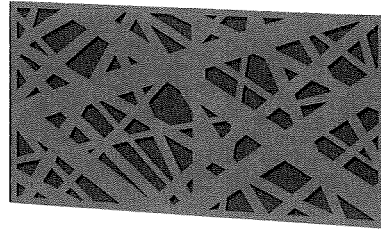

47" x 94"

47" x 84"

47" x 70"

47" x 47"

23.5" x 47"

## ECHODECO® D005 - DASH

### D005 - DASH SIZES

- 23.5"W x 47"H
- 47"W x 23.5"H
- 47"W x 47"H
- 47"W x 70"H
- 70"W x 47"H
- 47"W x 84"H
- 84"W x 47"H
- 47"W x 94"H
- 94"W x 47"H

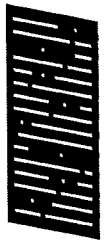
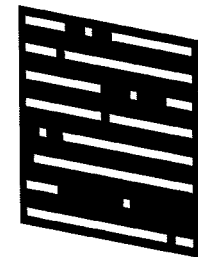
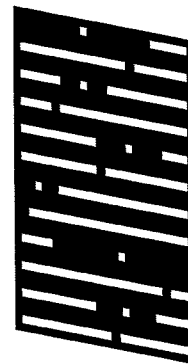
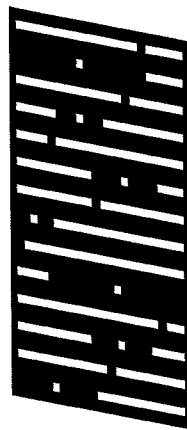
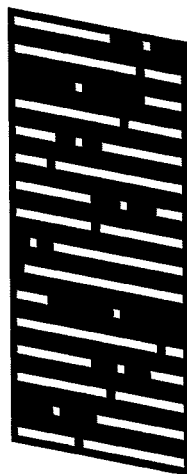
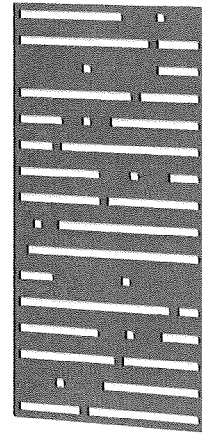
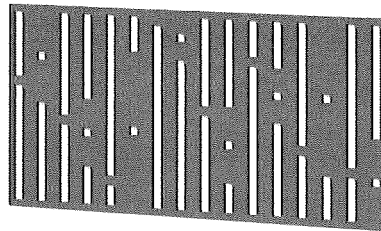

47" x 94"

47" x 84"

47" x 70"

47" x 47"

23.5" x 47"

ECHODECO® WALL PANEL DESIGNS

ECHODECO®  
D006 - PEBBLES

**D006 - PEBBLES  
SIZES**

- 23.5"W x 47"H
- 47"W x 23.5"H
- 47"W x 47"H
- 47"W x 70"H
- 70"W x 47"H
- 47"W x 84"H
- 84"W x 47"H
- 47"W x 94"H
- 94"W x 47"H

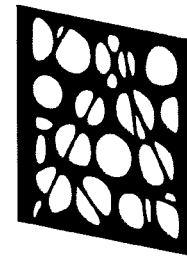
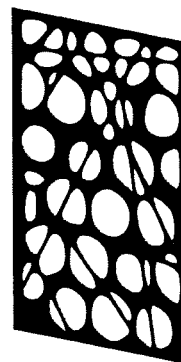
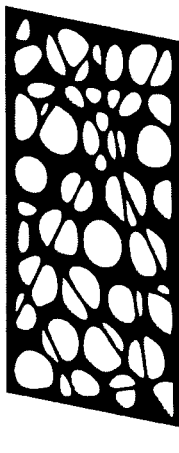
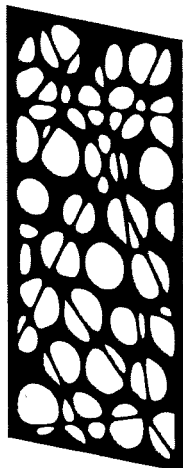
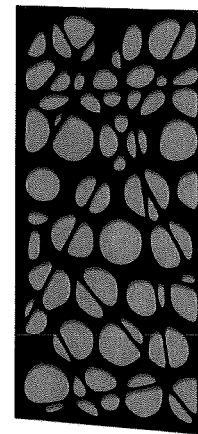
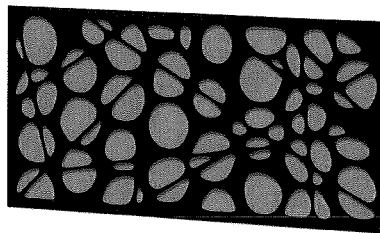

47" x 47"

23.5" x 47"

47" x 70"

47" x 84"

47" x 94"

ECHODECO®  
D009 - BRANCHES

**D009 - BRANCHES  
SIZES**

- 23.5"W x 47"H
- 47"W x 23.5"H
- 47"W x 47"H
- 47"W x 70"H
- 70"W x 47"H
- 47"W x 84"H
- 84"W x 47"H
- 47"W x 94"H
- 94"W x 47"H

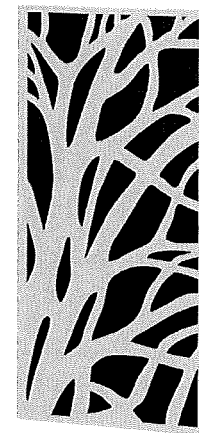
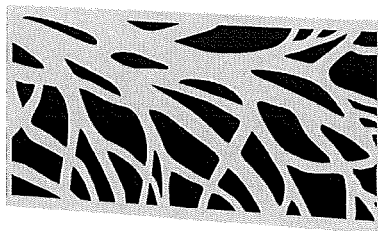

47" x 47"

23.5" x 47"

47" x 70"

47" x 84"

47" x 94"

# ECHODECO® WALL PANEL DESIGNS

## ECHODECO® D010 - CONSTELLATION

### D010 - CONSTELLATION SIZES

- 23.5"W x 47"H
- 47"W x 23.5"H
- 47"W x 47"H
- 47"W x 70"H
- 70"W x 47"H
- 47"W x 84"H
- 84"W x 47"W
- 47"W x 94"H
- 94"W x 47"H

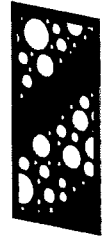
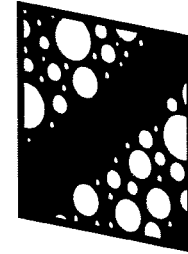
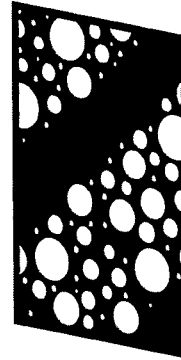
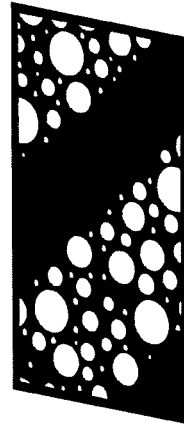
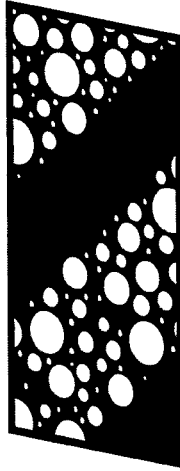
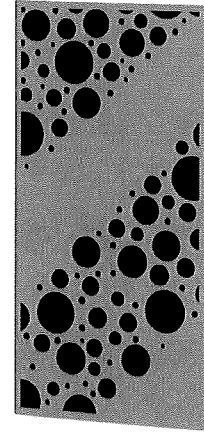
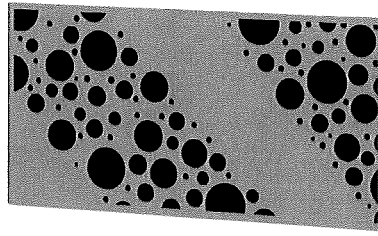

47" x 94"

47" x 84"

47" x 70"

47" x 47"

23.5" x 47"

## ECHODECO® D016 - RETRO

### D016 - RETRO SIZES

- 23.5"W x 47"H
- 47"W x 23.5"H
- 47"W x 47"H
- 47"W x 70"H
- 70"W x 47"H
- 47"W x 84"H
- 84"W x 47"W
- 47"W x 94"H
- 94"W x 47"H

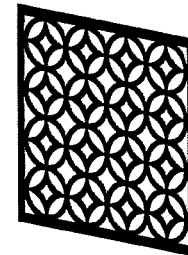
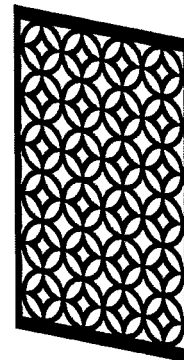
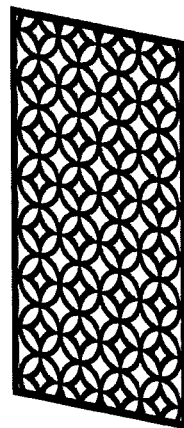
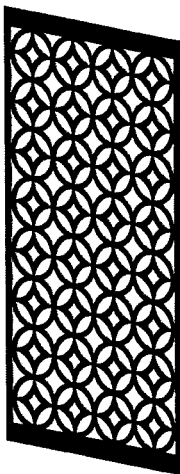
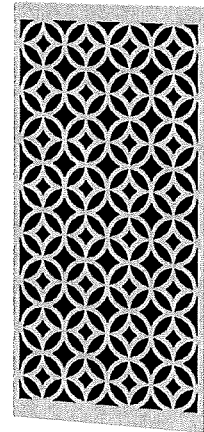
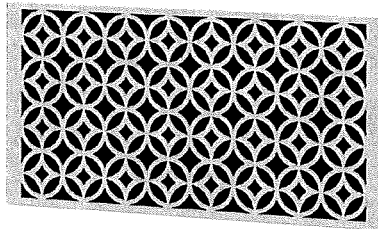

47" x 94"

47" x 84"

47" x 70"

47" x 47"

23.5" x 47"

ECHODECO® WALL PANEL DESIGNS

ECHODECO®  
D017 - STRATA

**D017 - STRATA  
SIZES**

- 23.5"W x 47"H
- 47"W x 23.5"H
- 47"W x 47"H
- 47"W x 70"H
- 70"W x 47"H
- 47"W x 84"H
- 84"W x 47"W
- 47"W x 94"H
- 94"W x 47"H

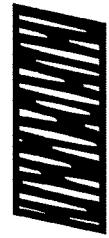
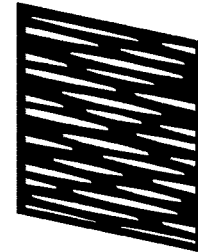
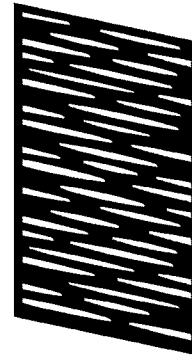
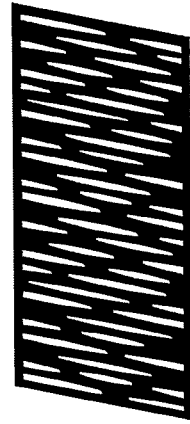
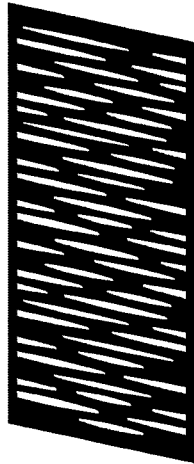
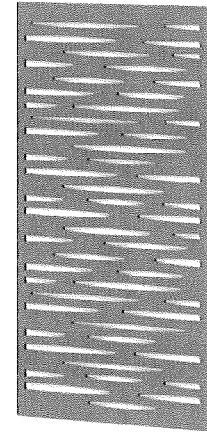
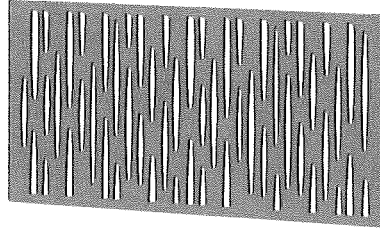

47" x 94"

47" x 84"

47" x 70"

47" x 47"

23.5" x 47"

ECHODECO®  
D019 - HONEYCOMB

**D019 - HONEYCOMB  
SIZES**

- 23.5"W x 47"H
- 47"W x 23.5"H
- 47"W x 47"H
- 47"W x 70"H
- 70"W x 47"H
- 47"W x 84"H
- 84"W x 47"W
- 47"W x 94"H
- 94"W x 47"H

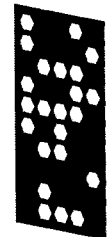
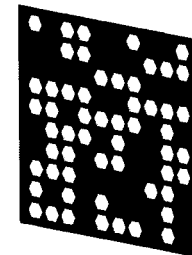
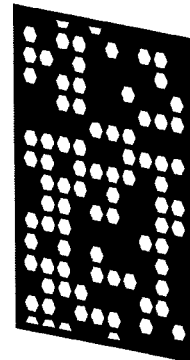
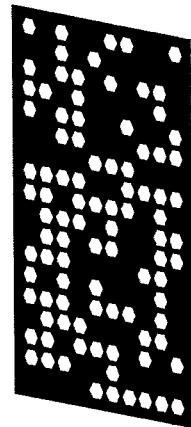
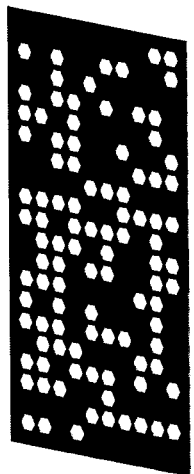
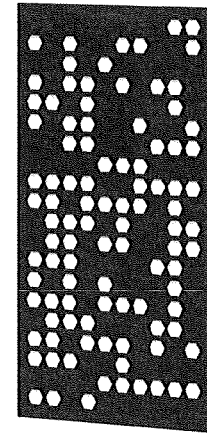
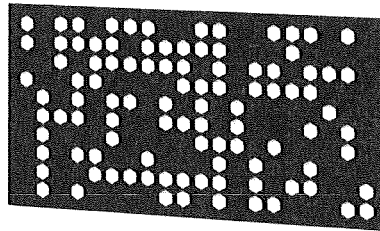

47" x 94"

47" x 84"

47" x 70"

47" x 47"

23.5" x 47"

ECHODECO® WALL PANEL DESIGNS

ECHODECO®  
D020 - FIESTA

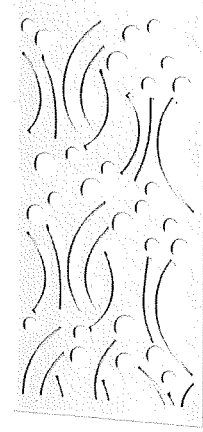
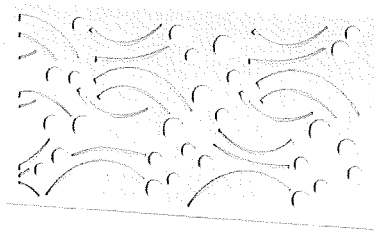

**D020 - FIESTA  
SIZES**

- 23.5"W x 47"H
- 47"W x 23.5"H
- 47"W x 47"H
- 47"W x 70"H
- 70"W x 47"H
- 47"W x 84"H
- 84"W x 47"W
- 47"W x 94"H
- 94"W x 47"H

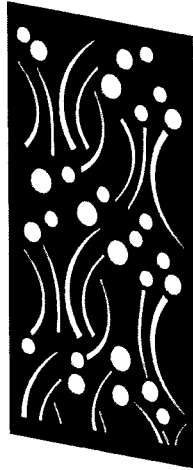

47" x 94"

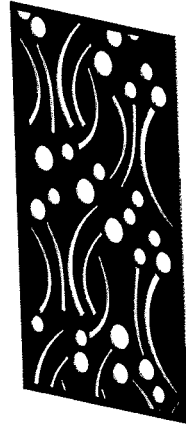

47" x 84"

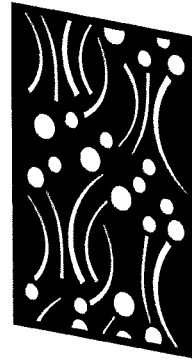

47" x 70"

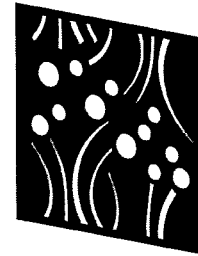

47" x 47"



23.5" x 47"

ECHODECO®  
D021 - MAZE

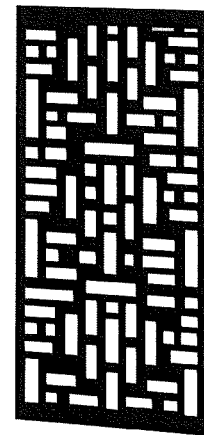
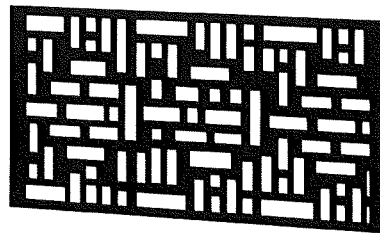

**D021 - MAZE  
SIZES**

- 23.5"W x 47"H
- 47"W x 23.5"H
- 47"W x 47"H
- 47"W x 70"H
- 70"W x 47"H
- 47"W x 84"H
- 84"W x 47"W
- 47"W x 94"H
- 94"W x 47"H

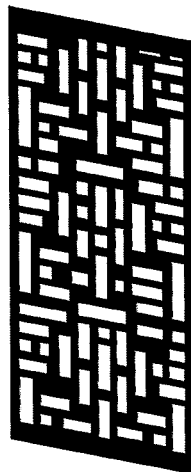

47" x 94"

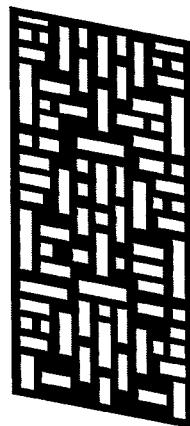

47" x 84"

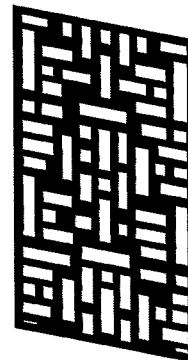

47" x 70"

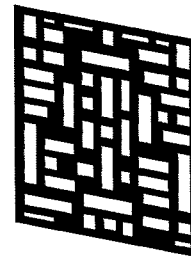

47" x 47"

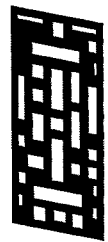

23.5" x 47"



# ECHODECO® WALL PANEL DESIGNS

## ECHODECO® D023 - PINWHEEL

### D023 - PINWHEEL SIZES

- 23.5"W x 47"H
- 47"W x 23.5"H
- 47"W x 47"H
- 47"W x 70"H
- 70"W x 47"H
- 47"W x 84"H
- 84"W x 47"H
- 47"W x 94"H
- 94"W x 47"H

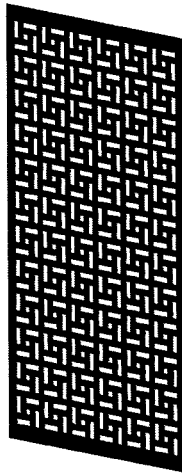
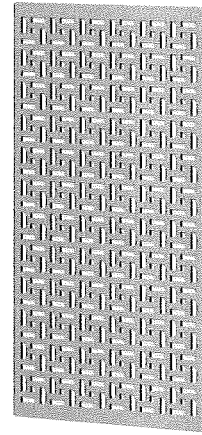
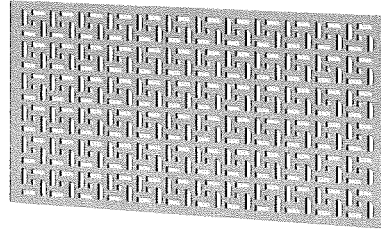

47" x 94"

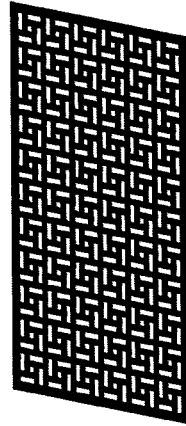

47" x 84"

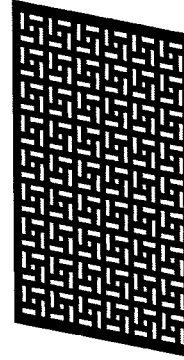

47" x 70"

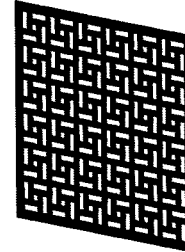

47" x 47"

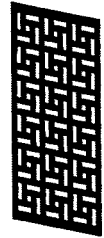

23.5" x 47"

## ECHODECO® D024 - FLEXAGON

### D024 - FLEXAGON SIZES

- 23.5"W x 47"H
- 47"W x 23.5"H
- 47"W x 47"H
- 47"W x 70"H
- 70"W x 47"H
- 47"W x 84"H
- 84"W x 47"H
- 47"W x 94"H
- 94"W x 47"H

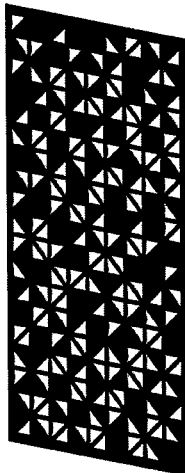
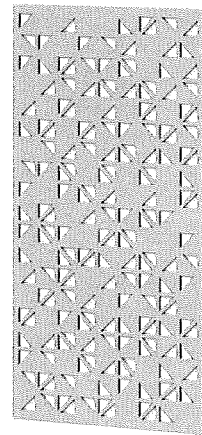
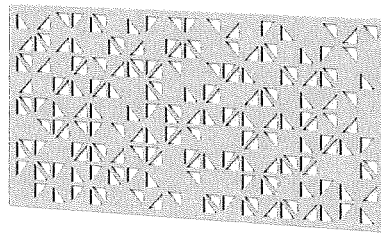

47" x 94"

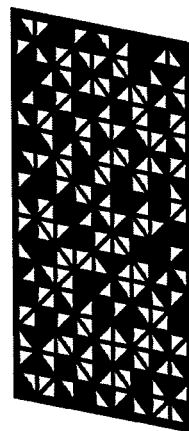

47" x 84"

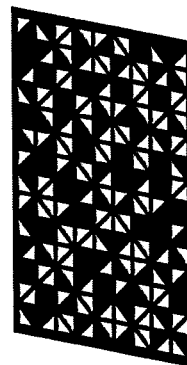

47" x 70"

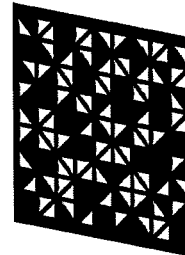

47" x 47"

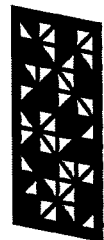

23.5" x 47"

# ECHODECO® WALL PANEL DESIGNS

## ECHODECO® D025 - BURST

### D025 - BURST SIZES

- 23.5"W x 47"H
- 47"W x 23.5"H
- 47"W x 47"H
- 47"W x 70"H
- 70"W x 47"H
- 47"W x 84"H
- 84"W x 47"H
- 47"W x 94"H
- 94"W x 47"H

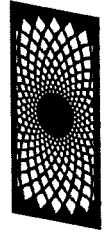
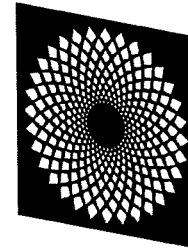
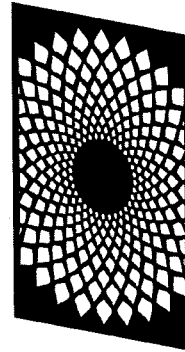
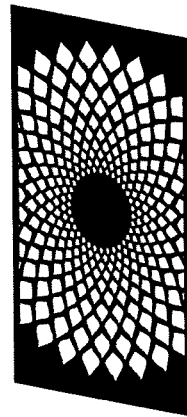
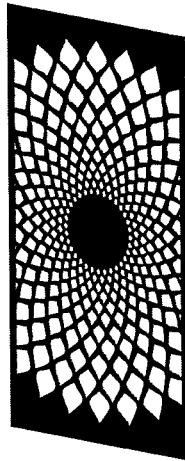
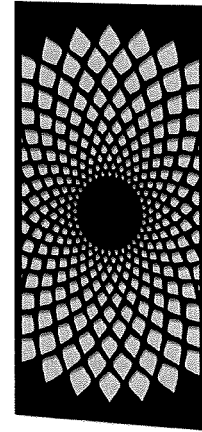
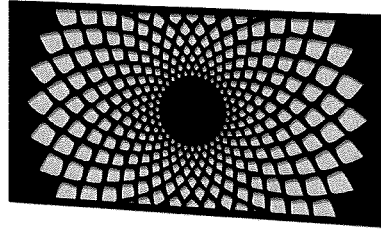

47" x 94"

47" x 84"

47" x 70"

47" x 47"

23.5" x 47"

## ECHODECO® D026 - PROPEL

### D026 - PROPEL SIZES

- 23.5"W x 47"H
- 47"W x 23.5"H
- 47"W x 47"H
- 47"W x 70"H
- 70"W x 47"H
- 47"W x 84"H
- 84"W x 47"H
- 47"W x 94"H
- 94"W x 47"H

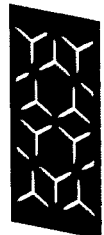
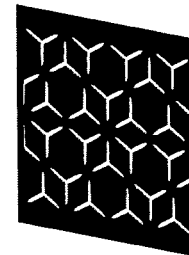
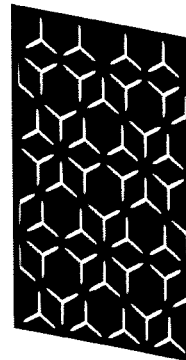
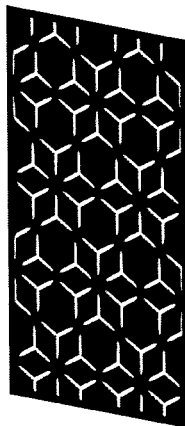
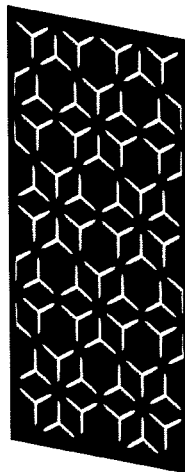
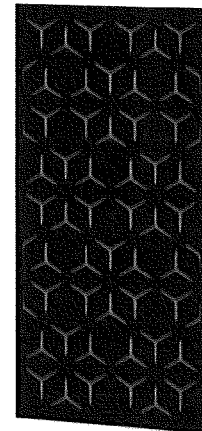
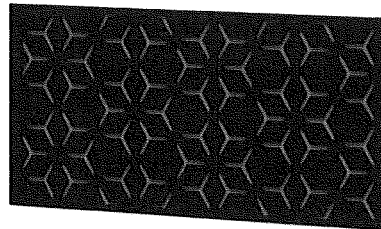

47" x 94"

47" x 84"

47" x 70"

47" x 47"

23.5" x 47"

# ECHODECO® WALL PANEL DESIGNS

## ECHODECO® D027 - SCALE

### D027 - SCALE SIZES

- 23.5"W x 47"H
- 47"W x 23.5"H
- 47"W x 47"H
- 47"W x 70"H
- 70"W x 47"H
- 47"W x 84"H
- 84"W x 47"H
- 47"W x 94"H
- 94"W x 47"H

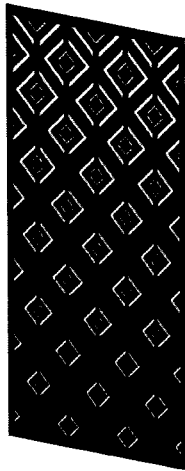
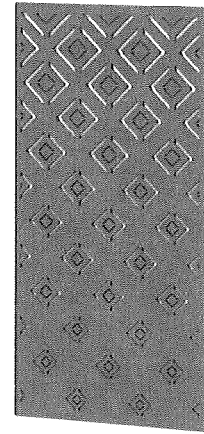
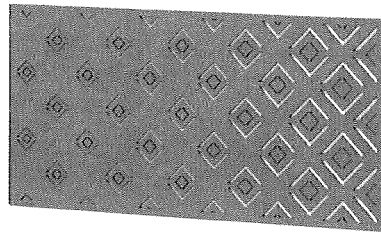

47" x 94"

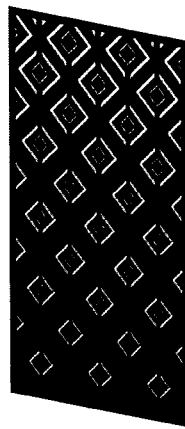

47" x 84"

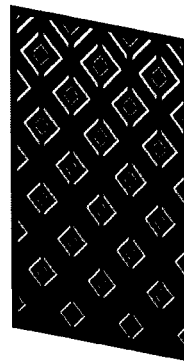

47" x 70"

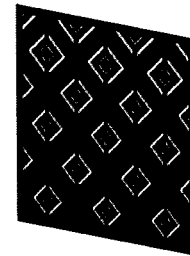

47" x 47"



23.5" x 47"

## ECHODECO® D028 - FLIGHT

### D028 - FLIGHT SIZES

- 23.5"W x 47"H
- 47"W x 23.5"H
- 47"W x 47"H
- 47"W x 70"H
- 70"W x 47"H
- 47"W x 84"H
- 84"W x 47"H
- 47"W x 94"H
- 94"W x 47"H

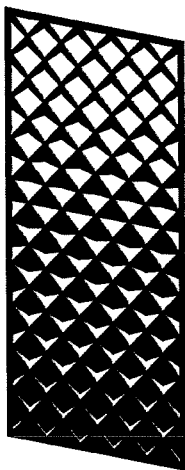
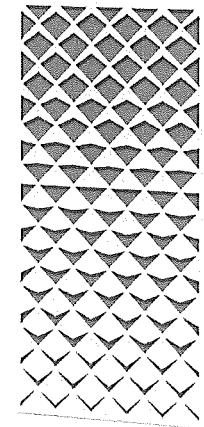
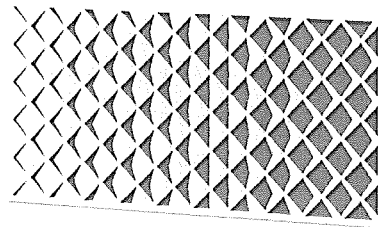

47" x 94"

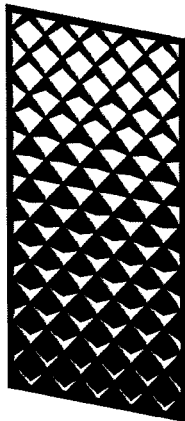

47" x 84"

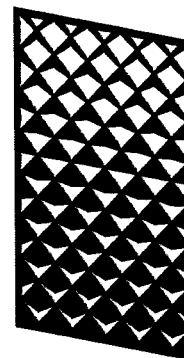

47" x 70"

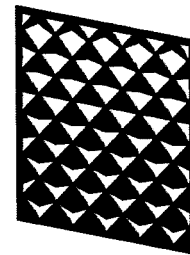

47" x 47"



23.5" x 47"

# ECHODECO® WALL PANEL DESIGNS

## ECHODECO® D029 - AUTUMN

### D029 - AUTUMN SIZES

- 23.5"W x 47"H
- 47"W x 23.5"H
- 47"W x 47"H
- 47"W x 70"H
- 70"W x 47"H
- 47"W x 84"H
- 84"W x 47"H
- 47"W x 94"H
- 94"W x 47"H

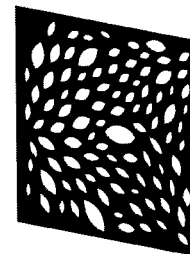
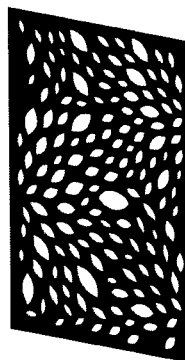
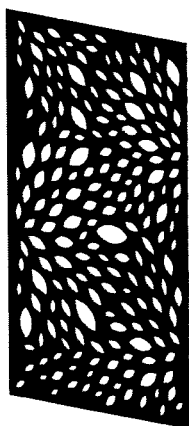
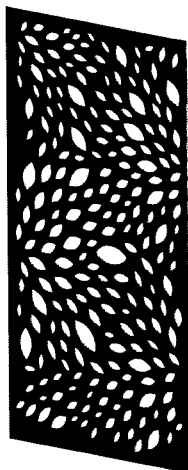
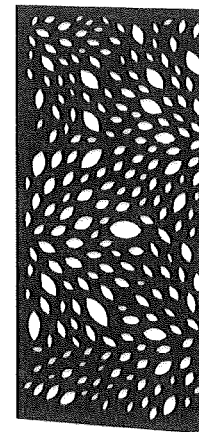
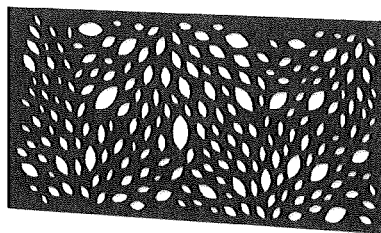

47" x 94"

47" x 84"

47" x 70"

47" x 47"

23.5" x 47"

## ECHODECO® D030 - BANNER

### D030 - BANNER SIZES

- 23.5"W x 47"H
- 47"W x 23.5"H
- 47"W x 47"H
- 47"W x 70"H
- 70"W x 47"H
- 47"W x 84"H
- 84"W x 47"H
- 47"W x 94"H
- 94"W x 47"H

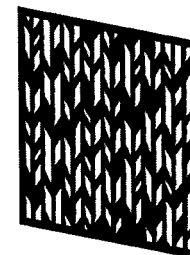
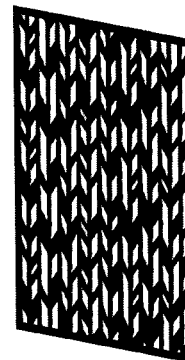
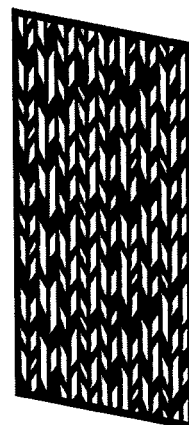
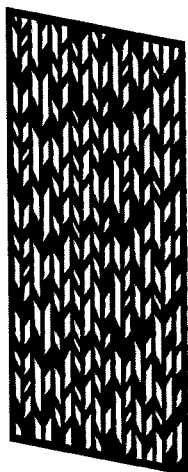
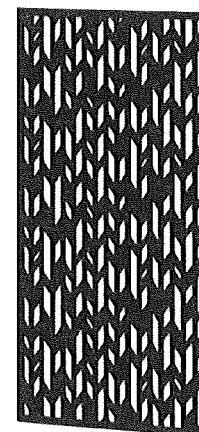
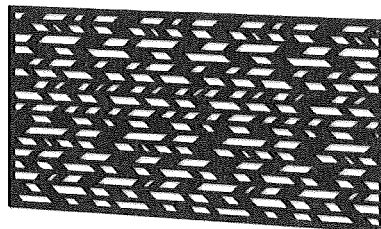

47" x 94"

47" x 84"

47" x 70"

47" x 47"

23.5" x 47"

# ECHODECO® WALL PANEL DESIGNS

## ECHODECO® D031 - ART DECO

### D031 - ART DECO SIZES

- 23.5"W x 47"H
- 47"W x 23.5"H
- 47"W x 47"H
- 47"W x 70"H
- 70"W x 47"H
- 47"W x 84"H
- 84"W x 47"H
- 47"W x 94"H
- 94"W x 47"H

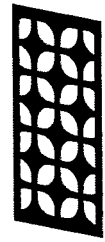
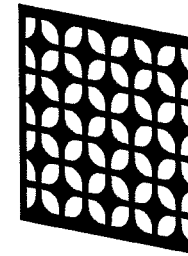
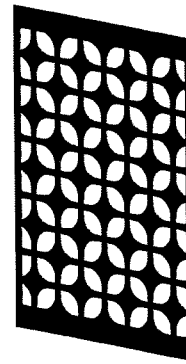
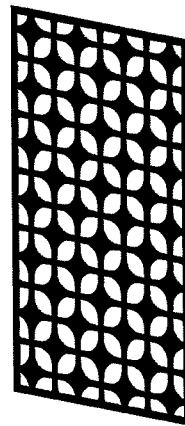
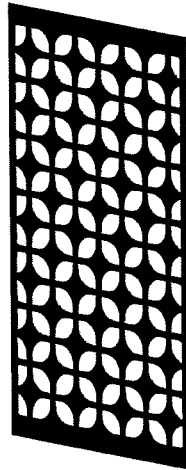
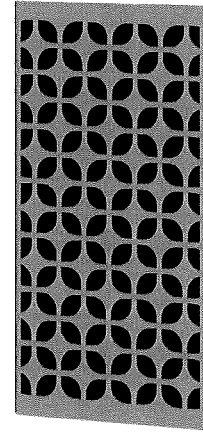
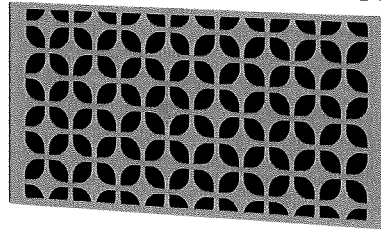

47" x 47"

23.5" x 47"

47" x 84"

47" x 70"

47" x 94"

## ECHODECO® D032 - MELODY

### D032 - MELODY SIZES

- 23.5"W x 47"H
- 47"W x 23.5"H
- 47"W x 47"H
- 47"W x 70"H
- 70"W x 47"H
- 47"W x 84"H
- 84"W x 47"H
- 47"W x 94"H
- 94"W x 47"H

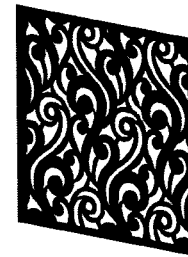
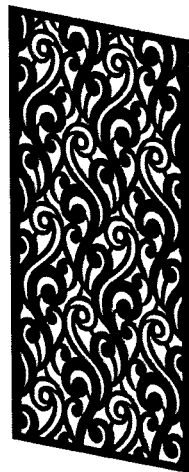
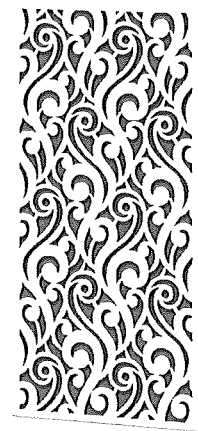
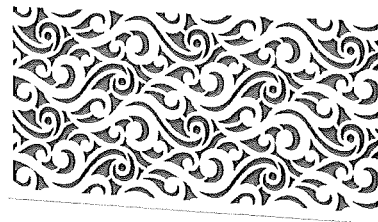

47" x 47"

23.5" x 47"

47" x 84"

47" x 70"

47" x 94"

ECHODECO® WALL PANEL DESIGNS

ECHODECO®  
D033 - WINTER

**D033 - WINTER  
SIZES**

- 23.5"W x 47"H
- 47"W x 23.5"H
- 47"W x 47"H
- 47"W x 70"H
- 70"W x 47"H
- 47"W x 84"H
- 84"W x 47"H
- 47"W x 94"H
- 94"W x 47"H

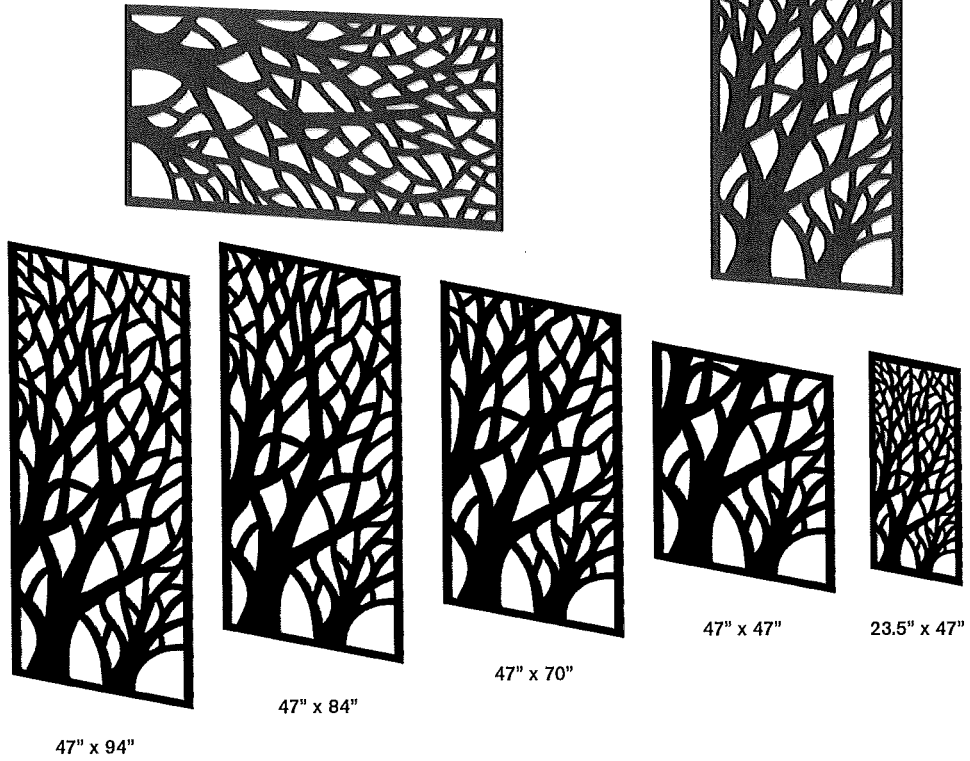

ECHODECO®  
D034 - PULSE

**D034 - PULSE  
SIZES**

- 23.5"W x 47"H
- 47"W x 23.5"H
- 47"W x 47"H
- 47"W x 70"H
- 70"W x 47"H
- 47"W x 84"H
- 84"W x 47"H
- 47"W x 94"H
- 94"W x 47"H

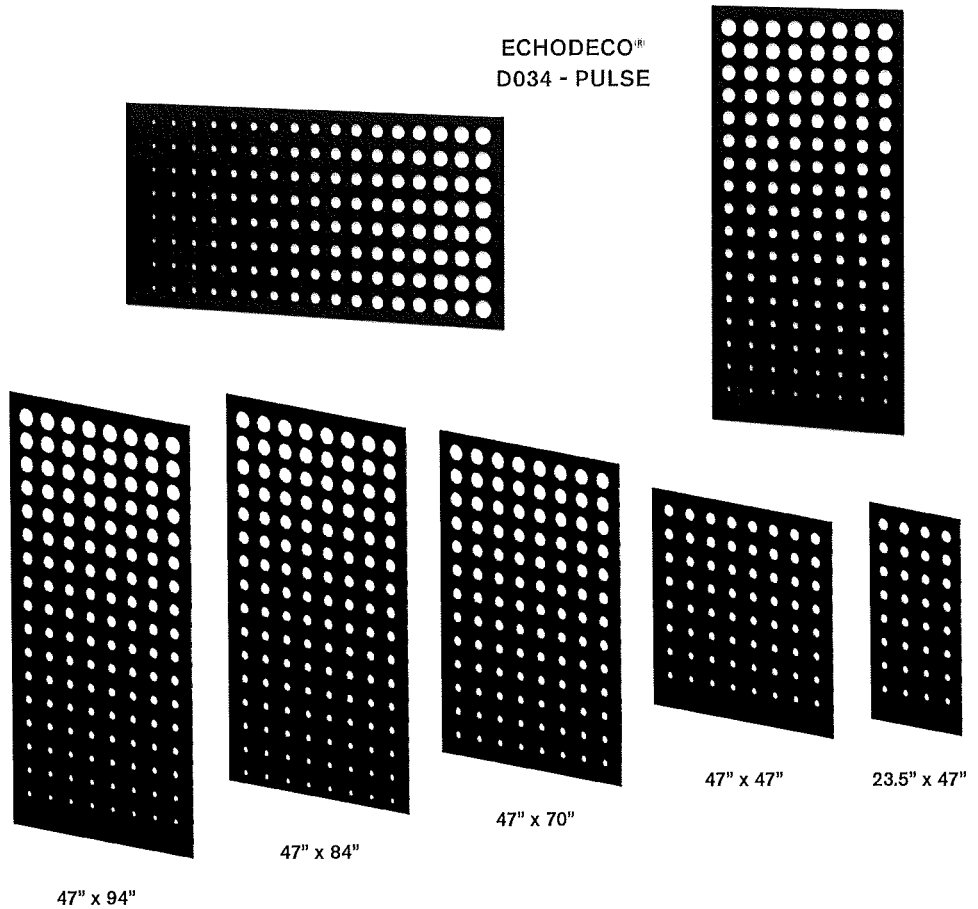

# ECHODECO® WALL PANEL DESIGNS

## ECHODECO® D035 - ICICLE

### D035 - ICICLE SIZES

- 23.5"W x 47"H
- 47"W x 23.5"H
- 47"W x 47"H
- 47"W x 70"H
- 70"W x 47"H
- 47"W x 84"H
- 84"W x 47"H
- 47"W x 94"H
- 94"W x 47"H

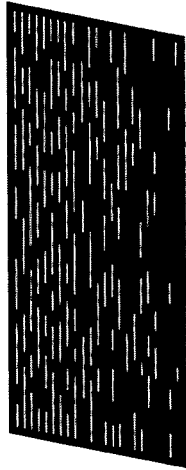
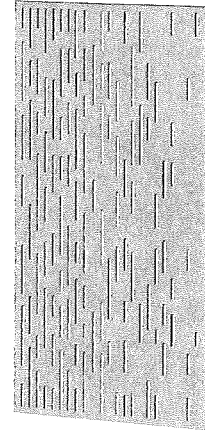
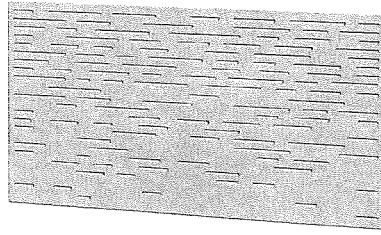

47" x 94"

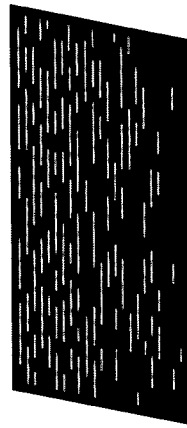

47" x 84"

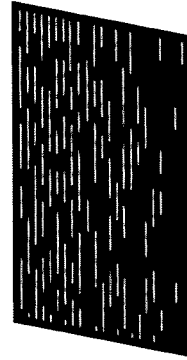

47" x 70"

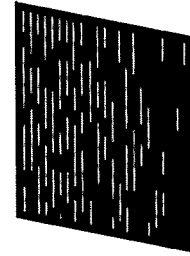

47" x 47"



23.5" x 47"

## ECHODECO® D036 - ORBIT

### D036 - ORBIT SIZES

- 23.5"W x 47"H
- 47"W x 23.5"H
- 47"W x 47"H
- 47"W x 70"H
- 70"W x 47"H
- 47"W x 84"H
- 84"W x 47"H
- 47"W x 94"H
- 94"W x 47"H

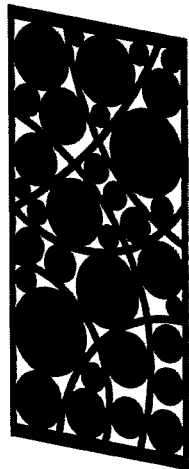
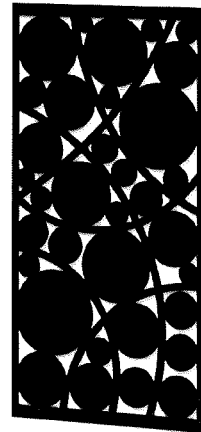
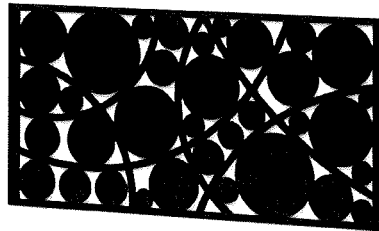

47" x 94"

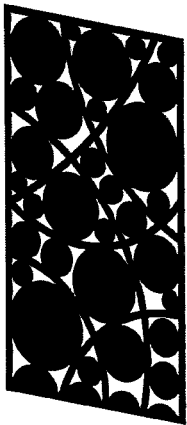

47" x 84"

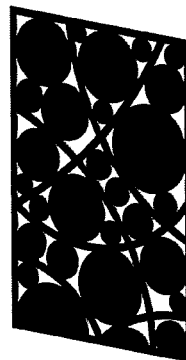

47" x 70"

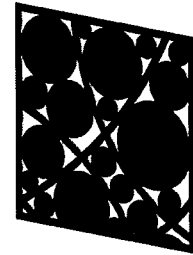

47" x 47"



23.5" x 47"

# ECHODECO® WALL PANEL DESIGNS

## ECHODECO® D037 - WEAVE

### D037 - WEAVE SIZES

- 23.5"W x 47"H
- 47"W x 23.5"H
- 47"W x 47"H
- 47"W x 70"H
- 70"W x 47"H
- 47"W x 84"H
- 84"W x 47"W
- 47"W x 94"H
- 94"W x 47"H

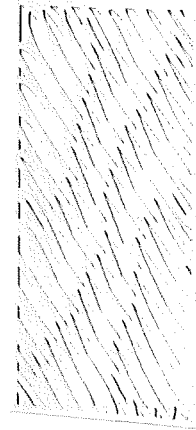
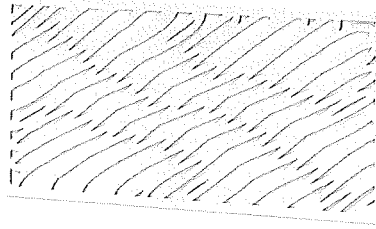

47" x 94"



47" x 84"



47" x 70"



47" x 47"



23.5" x 47"

## ECHODECO® D038 - GRATE

### D038 - GRATE SIZES

- 23.5"W x 47"H
- 47"W x 23.5"H
- 47"W x 47"H
- 47"W x 70"H
- 70"W x 47"H
- 47"W x 84"H
- 84"W x 47"W
- 47"W x 94"H
- 94"W x 47"H

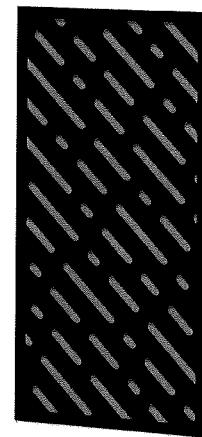
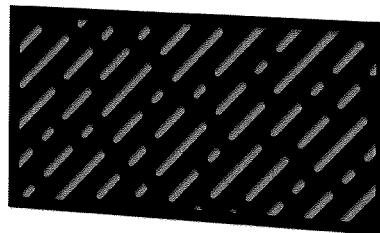

47" x 94"



47" x 84"

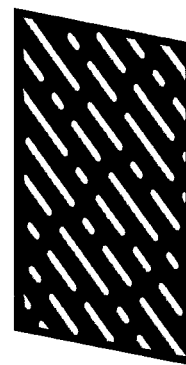

47" x 70"



47" x 47"



23.5" x 47"



# ECHODECO® WALL PANEL DESIGNS

## ECHODECO® D039 - PLUME

### D039 - PLUME SIZES

- 23.5"W x 47"H
- 47"W x 23.5"H
- 47"W x 47"H
- 47"W x 70"H
- 70"W x 47"H
- 47"W x 84"H
- 84"W x 47"W
- 47"W x 94"H
- 94"W x 47"H

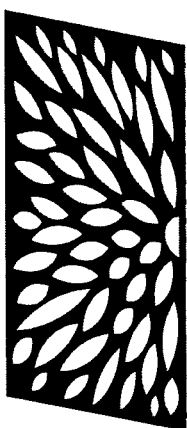
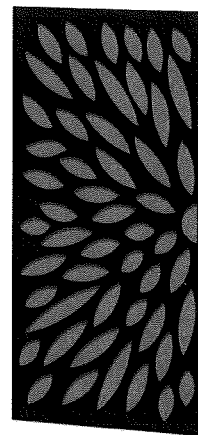
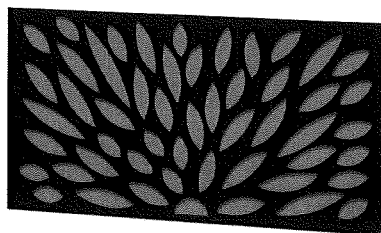

47" x 94"

47" x 84"

47" x 70"

47" x 47"

23.5" x 47"

## ECHODECO® D040 - CODE

### D040 - CODE SIZES

- 23.5"W x 47"H
- 47"W x 23.5"H
- 47"W x 47"H
- 47"W x 70"H
- 70"W x 47"H
- 47"W x 84"H
- 84"W x 47"W
- 47"W x 94"H
- 94"W x 47"H

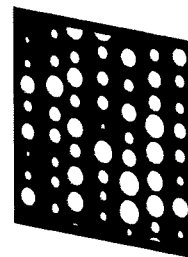
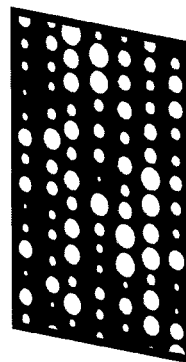
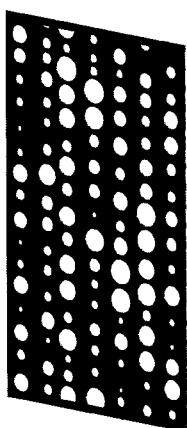
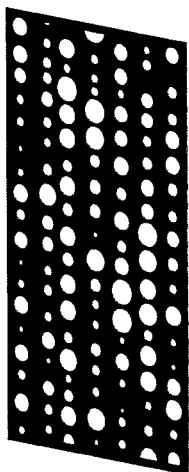
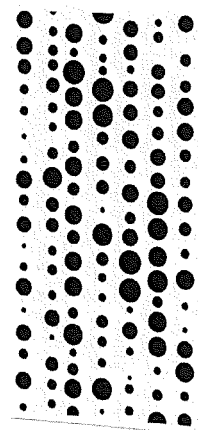
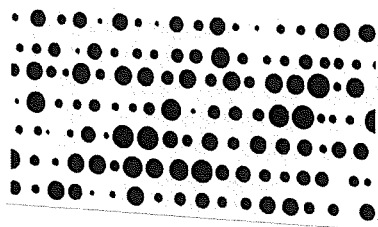

47" x 94"

47" x 84"

47" x 70"

47" x 47"

23.5" x 47"

# MOUNTING OPTIONS

## CEILING MOUNT OPTIONS

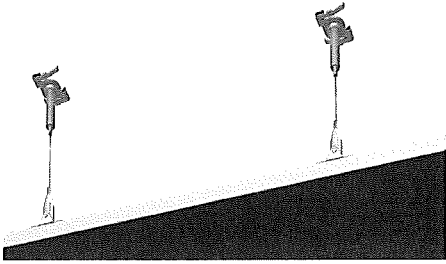

**ACT GRID CEILING MOUNT  
(G)**  
\*Compatible with standard  
1" (15/16") ceiling grids

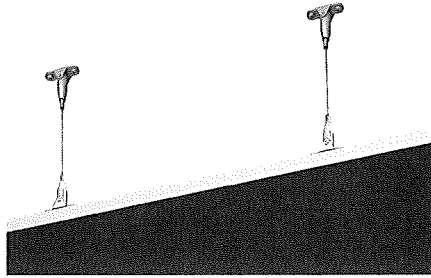

**PERMANENT MOUNT  
(P)**

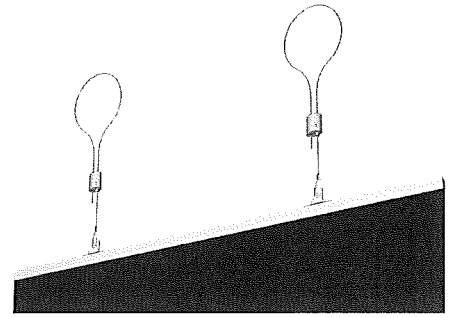

**LOOP MOUNT  
(L)**

## WALL MOUNT OPTIONS



**ECHODECO®  
STRAP MOUNT  
(SM3)**

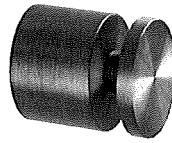

SILVER (SSO)

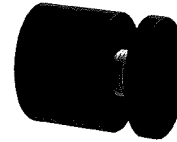

BLACK (BSO)

**ECHODECO®  
STANDOFF MOUNT**

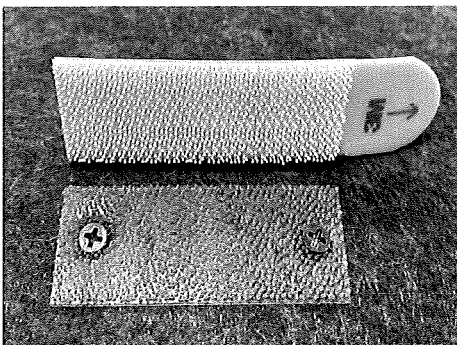

**ADHESIVE REMOVABLE MOUNT  
(W.R)**

**COMMAND™ STRIP  
WALL ADHESIVE**

COMMAND™ STRIP WALL ADHESIVE CAN BE USED ON THE FOLLOWING SURFACES: PAINTED, STAINED OR VARNISHED WOOD, GLASS, TILE, PAINTED CINDER BLOCK, PLASTER, METAL, AND PAINTED WALLBOARD.

**PRESS LOCK  
ADHESIVE STRIP**

PRESS LOCK ADHESIVE ATTACHES TO PRODUCT WITH ADHESIVE AND TWO SCREWS (SCREW INSTALLATION REQUIRED)

# MATERIAL OPTIONS

## ECHOSCAPE™ 3/8" (9MM)

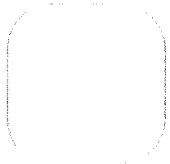

Snow  
P114

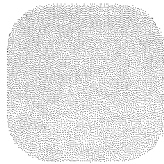

Overcast  
P124

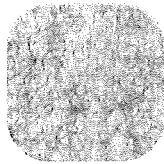

Iced Grey  
P106



Ash  
P100

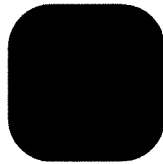

Slate  
P105

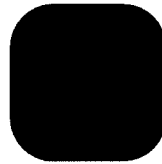

Charcoal  
P101

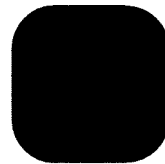

Jet  
P122

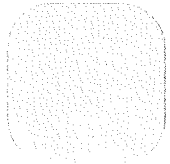

Canvas  
P126

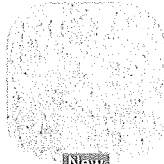

**New**  
Parchment  
P130

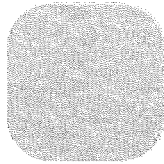

Oat  
P116



**New**  
Smoke  
P129



**New**  
Clay  
P128

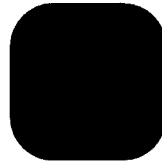

Cocoa  
P121

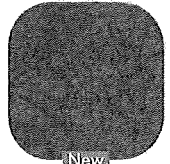

**New**  
Arctic  
P127

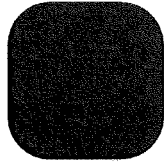

Spruce  
P123

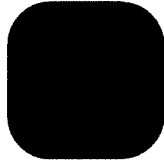

Denim  
P118

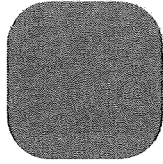

Sky  
P117

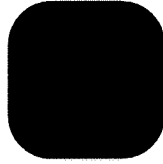

Cobalt  
P102

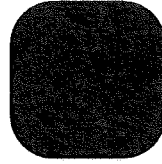

Blueprint  
P125

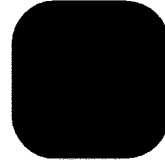

Midnight  
P119

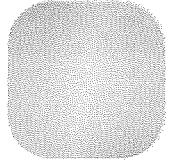

Sunflower  
P111

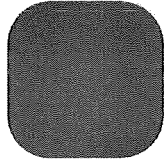

Tangerine  
P109



Ruby  
P108

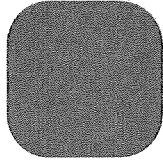

Aqua  
P115

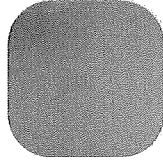

Pear  
P103

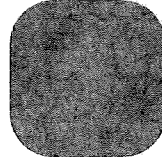

Moss  
P120

## ECHOSCAPE™ 3/4" (18MM)



Oat  
P316

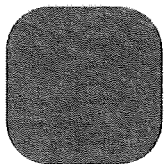

Sandstone  
P304

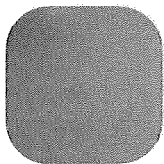

Pear  
P303



Spruce  
P323



Denim  
P318

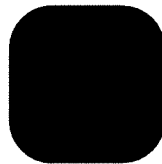

Cobalt  
P302

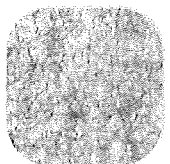

Iced Grey  
P306



Ash  
P300

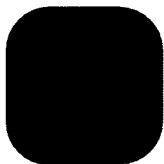

Slate  
P305

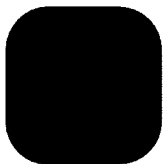

Charcoal  
P301



**MERGEWORKS**

# LIMITED WARRANTY

Merge Office Interiors, Inc., d/b/a MergeWorks, ("Company") takes great pride in our workmanship and the high quality of our products. We warrant that your new product is free from defects in materials or workmanship, subject to the limitations, exclusions, and other provisions detailed below. This limited warranty only applies to Company products purchased directly from an authorized Company dealer, for the original purchaser. The limited warranty is terminated upon transfer, sale, or modification of the product.

## Limitations involving particular materials and components:

The materials and components listed below are warranted according to the following schedule from the original date of shipping, but in no event exceeding the original manufacturer's warranty where applicable:

PRODUCT	MATERIAL	TERM OF WARRANTY
Desk Dividers	Fabric, Acrylic, TrueBrite Whiteboard, EchoScape	7 years
Whiteboards, Glass Boards, Urban Walls, Villa Walls, Duplex Walls	All materials	10 years
Acoustic Products	EchoScape 9MM & 18MM	3 years
Stackers, Modesty Panels	EchoScape & Acrylic	5 years
Worksurfaces	Series 100 & 300 Laminates	5 years
Worksurfaces	Thermal Fused Laminate (TFL)	2 years
Table Bases (Height adjustable and stationary)	Excluding electrical and pneumatic components	7 years
Electrical & Pneumatic Components	Height adjustable table bases, monitor arms, power strips, etc.	2 years
Non-electrical Accessories	Wire baskets, wire management trays, table connectors, CPU storage, accessory trays, clips, cups, etc.	7 years
Frames, Clamps & Mounting Hardware		10 years

## Exclusions:

This limited warranty does not apply, and no other warranty applies to:

- Normal wear and tear, which are to be expected over the course of ownership.
- Damage caused by abuse, misuse, neglect, vandalism, accident, disaster, improper storage, improper cleaning, chemical damage, water, fire electrical surges, environmental factors or discoloration due to sunlight or indoor lighting.
- Damage caused by the carrier in-transit, which will be handled as claims against the carrier.
- Products which have been modified, altered, repaired or refurbished by someone other than Company, attachments to the product that are not approved by Company or use of a product in combination with products or equipment not appropriate for that product.
- Products that were not installed, used or maintained in accordance with product instructions and warnings.
- Products used for rental purposes.



MERGEWORKS

# LIMITED WARRANTY

- Variations in color. Dye lots often vary and therefore we cannot be held responsible for color variations due to different order times. If an exact color match is required, customer service must be notified in advance of order placement.
- Products made with Customer's Own Material (COM products) or materials not standardly offered by Company.
- Custom products may be covered, at Company's sole discretion.

In the event of repair and/or replacement of any defective product, Company does not warrant matching color, grain, texture or dye lots.

If a product is defective in materials or workmanship, Company will replace or repair it subject to the provisions herein. This is your sole and exclusive remedy, and repair or replacement of the product will be at the sole discretion of Company. Shipping charges to the repair facility will be the responsibility of the purchaser, and shipping charges to return the repaired product to the purchaser will be paid by Company, except for products returned for repair during the first 35 days after the original ship date, in which case all shipping charges will be paid by Company. This limited warranty is subject to the limitations, exclusions, and other provisions herein, and applies to Company product purchased after September 1, 2019 which are delivered within the USA and Canada.

Company will not be responsible for incidental damages, repairs, labor or other costs incurred in removal, return or reinstallation of defective product. Any other loss, expense, or damage incurred in replacing any defective product will be the responsibility of purchaser.

## **DISCLAIMERS**

**TO THE EXTENT ALLOWED BY LAW, COMPANY MAKES NO WARRANTIES WHICH EXTEND BEYOND THE DESCRIPTION ON THE FACE HEREOF, EITHER EXPRESS OR IMPLIED, INCLUDING ANY WARRANTY OF MERCHANTABILITY OR WARRANTY OF FITNESS FOR A PARTICULAR PURPOSE.**

## **LIMITED LIABILITY**

**COMPANY WILL NOT BE LIABLE FOR ANY INDIRECT, CONSEQUENTIAL OR INCIDENTAL DAMAGES. COMPANY'S MAXIMUM LIABILITY ON ANY CLAIM IN ANY WAY CONNECTED WITH THE SALE OR USE OF ANY OF THE COMPANY'S PRODUCTS, WHETHER LIABILITY ARISES IN CONTRACT, FROM BREACH OF WARRANTY, IN TORT OR OTHERWISE, SHALL BE LIMITED TO THE PRODUCT'S INVOICE PRICE.**

### **To obtain service under this limited warranty:**

1. Contact your dealer within 30 days of discovery of the defect. Be prepared to prove you are the original purchaser of the product and provide your model number, and description of the defect. Then provide your company name, address, telephone number and Purchase Order if known.
2. Company will review all pertinent information regarding the claim with the dealer, including inspection of the product if deemed appropriate and recommend appropriate corrective remedies to the dealer.

**PRODUCTS RETURNED TO THE MERGEWORKS FACILITY WITHOUT A RETURN AUTHORIZATION WILL BE REFUSED. THIS LIMITED WARRANTY SUPERCEDES ALL PREVIOUS MERGEWORKS WARRANTIES.**



500 West Big Beaver  
Troy, MI 48084  
troymi.gov

# CITY COUNCIL AGENDA ITEM

**Date:** June 17, 2024

**To:** Robert J. Bruner, Acting City Manager

**From:** Megan E. Schubert, Assistant City Manager  
Rob Maleszyk, Chief Financial Officer  
Dee Ann Irby, Controller  
Kurt Bovensiep, Public Works Director  
Dennis E. Trantham, Deputy Public Works Director  
Brian Goul, Recreation Director  
Emily Frontera, Purchasing Manager

**Subject:** Standard Purchasing Resolution 1: Award to Sole Bidder – Acoustic Panel Replacement in the Senior Dining Room at the Troy Community Center

## History

- On September 1, 2022, the Oakland County Board of Commissioners passed resolution #22-280 Appropriating American Rescue Plan Act funding to support the Oakland Together Senior Initiatives. These initiatives included funding for the Senior Center Matching Grant Program.
- City Council approved the Interlocal Agreement between the City of Troy and the Board of Commissioners of the County of Oakland for the Senior Centers Matching Grant Program in the amount of \$250,000 at the April 10, 2023 meeting (Resolution #2023-04-056).
- The grant money is to be used to renovate the Senior Dining room and recondition the outdoor Bocce and Shuffleboard Courts at the Community Center.
- The Senior Dining Room will receive new hard flooring, upgraded LED lights, paint, new acoustic panels, blinds, TV, additional accessible door openers, signage, along with new furniture.
- The Bocce and Shuffleboard Court portion of the project will include replacement of the Shuffleboard Court and rehabilitation of the Bocce Ball Court.

## Purchasing

On June 13, 2024, a bid opening was conducted as required by City Charter/Code for the removal, replacement, and installation of new acoustic panels in the Senior Dining Room at the Community Center. The bid was posted on the MITN Purchasing Group website: [www.bidnetdirect.com//city-of-troy-mi](http://www.bidnetdirect.com//city-of-troy-mi). Three hundred and ninety-six (396) vendors were notified via the MITN website; one (1) bid proposal was received. Below is a detailed summary of potential vendors:

Companies notified via MITN	396	<p><i>MITN provides a resourceful online platform to streamline the procurement process, reduce costs, and make it easier and more transparent for vendors to do business with the City of Troy.</i></p> <p><b>Active MITN</b> members with a current membership and paying annual dues receive automatic electronic notification which allows instant access to Bids, RFPS and Quote opportunities with the City.</p> <p><b>Active MITN non-paying</b> members are responsible to monitor and check the MITN website for opportunities to do business with the City.</p> <p><b>Inactive MITN member</b> status can occur when a company does not renew their account upon expiration. Inactive members cannot be notified of solicitations or access any bid information.</p>
Troy Companies notified via MITN	12	
Troy Companies - Active email Notification	12	
Troy Companies - Active Free	0	
Companies that viewed the bid	20	
Troy Companies that viewed the bid	2	



500 West Big Beaver  
Troy, MI 48084  
troymi.gov

## CITY COUNCIL AGENDA ITEM

### **Purchasing (Continued)**

- *ISCG Inc of Royal Oak, MI* is the sole bidder meeting specifications and is being recommended for award. The alternate product provided in their bid proposal was determined to be an approved alternate per the following bid language:

*Approved Alternates: The City of Troy's Designated City Representative or his/her designee will review all items submitted for consideration as approved alternates. Their decision as to acceptability will be deemed in the City of Troy's best interest and will be final.*

- *ISCG Inc of Royal Oak, MI* has successfully performed work for the City of Troy and has met all requirements.

### **Financial**

Funds are budgeted and available in the Troy Community Center Building Improvements Capital Fund under Project Numbers 2024CG0001 for the 2024 Fiscal Year. Expenditures will be charged to account number 401.756.755.975.125.

### **Recommendation**

City Management recommends awarding a contract for the removal, replacement, and installation of the acoustic panels for the Senior Dining Room at the Community Center at a total estimated price of \$66,240 to sole bidder meeting specifications, *ISCG Inc. of Royal Oak, MI* at unit prices contained in the attached bid tabulation, opened June 13, 2024.

Opening Date: 06/13/2024  
 Date Reviewed: 06/13/2024

CITY OF TROY  
 BID TABULATION  
 ACOUSTIC WALL PANELS - SENIOR DINING ROOM

ITB-COT 24-10  
 Page 1 of 1

VENDOR NAME: ISCG INC  
 CITY: Royal Oak, MI

**PROPOSAL: TO PROVIDE AND INSTALL ACOUSTIC WALL PANELS IN THE SENIOR DINING ROOM LOCATED AT THE TROY COMMUNITY CENTER**

DESCRIPTION	QTY	UNIT COST	EXTENDED COST
<b>*Alternate items/quantity submitted for proposal</b>			
<b>PROPOSAL A:</b> Removal and disposal of existing acoustical panels and any necessary wall repairs. If necessary, dumpster to be provided by vendor.	1	\$3,750.00	\$3,750.00
<b>PROPOSAL B:</b> Horizontal Panels: Solid Wall/Ceiling Panels Standard Solid Panels: 12mm 12mm (ST) Peach- Solid Color 110"H 42"W Adhesive Backer Added *9mm 84"W X 47"H	57 *73	\$450.00	\$32,850.00
<b>PROPOSAL C:</b> Pillar Panels: Solid Wall/Ceiling Panels Standard Solid Panels: 12mm 12mm (ST) Peach- Solid Color 110"H 30"W Adhesive Backer Added *9mm 72"W X 47"H	30 *27	\$345.00	\$9,315.00
<b>PROPOSAL D:</b> Attic Stock: Solid Wall/Ceiling Panels Standard Solid Panels: 12mm 12mm (ST) Peach- Solid Color 110"H 42"W Adhesive Backer Added *9mm 84"W X 47"H	3	\$450.00	\$1,350.00
<b>PROPOSAL E:</b> Attic Stock: Pillar Panels: Solid Wall/Ceiling Panels Standard Solid Panels: 12mm 12mm (ST) Peach- Solid Color 110"H 30"W Adhesive Backer Added *9mm 72"W X 47"H	2	\$345.00	\$690.00
<b>PROPOSAL F:</b> Installation Labor and Materials	1	\$17,500.00	\$17,500.00
Freight		\$785.00	\$785.00
<b>PROPOSALS A - F TOTAL COST:</b>		<b>\$66,240.00</b>	

Descriptive Literature Provided:	Y or N	Y
Can Provide Samples:	Y or N	Y
Can Meet Completion Date:	Y or N	N - Product lead time 4-6 wks from time ordered. Does not include transit time.
Warranty:		3 YEARS Product and Installation
<b>Contact Information:</b> Hours of Operation:		7 a.m. - 4 p.m.
Contact Phone #:		313-663-6073
References:		Y
Can Provide Insurance:	Y or N	Y
Payment Terms:	Y or N	Y
Delivery Date:		TBD Based on Order Date
Exceptions:		We are using 9mm thick Mergeworks Echo/Decho solid panels. Sheet Sizes are 70 x 47 & 84 x 47. Once awarded we can elaborate on how they will be applied. Pillars will have horizontal seam w/ an overall height of 94". All colors available & attached to this bid are the same price.
Acknowledgement:	Y or N	Y
Signed Addendum:		Y
Forms:	Y or N	Y

Attest:

(\*Bid Opening conducted via a Zoom Meeting)

\_\_\_\_\_  
 Brian Goul  
 \_\_\_\_\_  
 Andrew Chambliss  
 \_\_\_\_\_  
 Nellie Bert  
 \_\_\_\_\_  
 Martinique Gates

\_\_\_\_\_  
 Emily Frontera  
 Purchasing Department





# CERTIFICATE OF LIABILITY INSURANCE

DATE (MM/DD/YYYY)

1/16/2024

THIS CERTIFICATE IS ISSUED AS A MATTER OF INFORMATION ONLY AND CONFERS NO RIGHTS UPON THE CERTIFICATE HOLDER. THIS CERTIFICATE DOES NOT AFFIRMATIVELY OR NEGATIVELY AMEND, EXTEND OR ALTER THE COVERAGE AFFORDED BY THE POLICIES BELOW. THIS CERTIFICATE OF INSURANCE DOES NOT CONSTITUTE A CONTRACT BETWEEN THE ISSUING INSURER(S), AUTHORIZED REPRESENTATIVE OR PRODUCER, AND THE CERTIFICATE HOLDER.

**IMPORTANT:** If the certificate holder is an ADDITIONAL INSURED, the policy(ies) must have ADDITIONAL INSURED provisions or be endorsed. If SUBROGATION IS WAIVED, subject to the terms and conditions of the policy, certain policies may require an endorsement. A statement on this certificate does not confer rights to the certificate holder in lieu of such endorsement(s).

<b>PRODUCER</b> Meadowbrook Insurance Agency 26255 American Drive Southfield MI 48034  License#: PC779010	<b>CONTACT NAME:</b> Heather Barber <b>PHONE (A/C, No, Ext):</b> 248-204-6181 <b>FAX (A/C, No):</b> <b>E-MAIL ADDRESS:</b> heather.barber@meadowbrook.com													
	<table border="1"> <tr> <th>INSURER(S) AFFORDING COVERAGE</th> <th>NAIC #</th> </tr> <tr> <td>INSURER A: Employers Mutual Casualty Company</td> <td>21415</td> </tr> <tr> <td>INSURER B:</td> <td></td> </tr> <tr> <td>INSURER C:</td> <td></td> </tr> <tr> <td>INSURER D:</td> <td></td> </tr> <tr> <td>INSURER E:</td> <td></td> </tr> <tr> <td>INSURER F:</td> <td></td> </tr> </table>	INSURER(S) AFFORDING COVERAGE	NAIC #	INSURER A: Employers Mutual Casualty Company	21415	INSURER B:		INSURER C:		INSURER D:		INSURER E:		INSURER F:
INSURER(S) AFFORDING COVERAGE	NAIC #													
INSURER A: Employers Mutual Casualty Company	21415													
INSURER B:														
INSURER C:														
INSURER D:														
INSURER E:														
INSURER F:														
<b>INSURED</b> Interior Systems Contract Group, Inc. DBA ISCG 612 North Main Royal Oak MI 48067  INTESYS-01														

**COVERAGES**

CERTIFICATE NUMBER: 1630833044

REVISION NUMBER:

THIS IS TO CERTIFY THAT THE POLICIES OF INSURANCE LISTED BELOW HAVE BEEN ISSUED TO THE INSURED NAMED ABOVE FOR THE POLICY PERIOD INDICATED. NOTWITHSTANDING ANY REQUIREMENT, TERM OR CONDITION OF ANY CONTRACT OR OTHER DOCUMENT WITH RESPECT TO WHICH THIS CERTIFICATE MAY BE ISSUED OR MAY PERTAIN, THE INSURANCE AFFORDED BY THE POLICIES DESCRIBED HEREIN IS SUBJECT TO ALL THE TERMS, EXCLUSIONS AND CONDITIONS OF SUCH POLICIES. LIMITS SHOWN MAY HAVE BEEN REDUCED BY PAID CLAIMS.

INSR LTR	TYPE OF INSURANCE	ADDL INSD	SUBR WVD	POLICY NUMBER	POLICY EFF (MM/DD/YYYY)	POLICY EXP (MM/DD/YYYY)	LIMITS
A	<input checked="" type="checkbox"/> COMMERCIAL GENERAL LIABILITY <input type="checkbox"/> CLAIMS-MADE <input checked="" type="checkbox"/> OCCUR  GEN'L AGGREGATE LIMIT APPLIES PER: <input checked="" type="checkbox"/> POLICY <input type="checkbox"/> PRO-JECT <input type="checkbox"/> LOC OTHER:	Y		4D91453	4/1/2023	4/1/2024	EACH OCCURRENCE \$ 1,000,000 DAMAGE TO RENTED PREMISES (Ea occurrence) \$ 500,000 MED EXP (Any one person) \$ 10,000 PERSONAL & ADV INJURY \$ 1,000,000 GENERAL AGGREGATE \$ 2,000,000 PRODUCTS - COMP/OP AGG \$ 2,000,000 \$
A	<input checked="" type="checkbox"/> AUTOMOBILE LIABILITY <input checked="" type="checkbox"/> ANY AUTO <input type="checkbox"/> OWNED AUTOS ONLY <input checked="" type="checkbox"/> HIRED AUTOS ONLY <input type="checkbox"/> SCHEDULED AUTOS NON-OWNED AUTOS ONLY			4E91453	4/1/2023	4/1/2024	COMBINED SINGLE LIMIT (Ea accident) \$ 1,000,000 BODILY INJURY (Per person) \$ BODILY INJURY (Per accident) \$ PROPERTY DAMAGE (Per accident) \$ \$
A	<input checked="" type="checkbox"/> UMBRELLA LIAB <input checked="" type="checkbox"/> OCCUR <input type="checkbox"/> EXCESS LIAB <input type="checkbox"/> DED <input checked="" type="checkbox"/> RETENTION \$ 0			4J91453	4/1/2023	4/1/2024	EACH OCCURRENCE \$ 3,000,000 AGGREGATE \$ 3,000,000 \$
A	<input checked="" type="checkbox"/> WORKERS COMPENSATION AND EMPLOYERS' LIABILITY ANY PROPRIETOR/PARTNER/EXECUTIVE OFFICER/MEMBER EXCLUDED? (Mandatory in NH) If yes, describe under DESCRIPTION OF OPERATIONS below		Y	4H91453	4/1/2023	4/1/2024	<input checked="" type="checkbox"/> PER STATUTE <input type="checkbox"/> OTH-ER E.I. EACH ACCIDENT \$ 1,000,000 E.I. DISEASE - EA EMPLOYEE \$ 1,000,000 E.I. DISEASE - POLICY LIMIT \$ 1,000,000

DESCRIPTION OF OPERATIONS / LOCATIONS / VEHICLES (ACORD 101, Additional Remarks Schedule, may be attached if more space is required)

GENERAL LIABILITY - Form CG7578 (02/19) applies:  
 Blanket Additional Insured status provided when required by contract  
 Blanket Waiver of Subrogation provided when required by contract  
 Primary & NonContributory coverage included

AUTO LIABILITY - Form CA7270 (11/17) applies:  
 Blanket Additional Insured status provided when required by contract

See Attached...

**CERTIFICATE HOLDER****CANCELLATION**

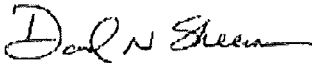
City of Troy 500 W. Big Beaver Road Troy MI 48084	SHOULD ANY OF THE ABOVE DESCRIBED POLICIES BE CANCELLED BEFORE THE EXPIRATION DATE THEREOF, NOTICE WILL BE DELIVERED IN ACCORDANCE WITH THE POLICY PROVISIONS.  AUTHORIZED REPRESENTATIVE 
---	---

© 1988-2015 ACORD CORPORATION. All rights reserved.

AGENCY CUSTOMER ID: INTESYS-01

LOC #: \_\_\_\_\_



## ADDITIONAL REMARKS SCHEDULE

Page 1 of 1

AGENCY Meadowbrook Insurance Agency		NAMED INSURED Interior Systems Contract Group, Inc. DBA ISCG 612 North Main Royal Oak MI 48067	
POLICY NUMBER		EFFECTIVE DATE:	
CARRIER	NAIC CODE		

### ADDITIONAL REMARKS

THIS ADDITIONAL REMARKS FORM IS A SCHEDULE TO ACORD FORM,  
FORM NUMBER: 25 FORM TITLE: CERTIFICATE OF LIABILITY INSURANCE

City of Troy is additional insured under the general liability as per written contract and where their interests may appear. The policy is primary and non-contributory. A Waiver of Subrogation is provided as required. 30 days notice of cancellation and 10 days for non payment.



