

CITY COUNCIL MINUTES

June 10, 2024

**Standard Purchasing Resolution 2: Award to Low Bidder Meeting Specifications -
Water System Materials**

Resolution #2024-06-078-J-4b

RESOLVED, That Troy City Council hereby **AWARDS** a one (1) year contract to provide requirements of Water System Materials to the overall low bidder meeting specifications, *Core & Main of Shelby Twp., MI*, for an estimated total cost of \$242,065.00, at the unit prices contained in the bid tabulation opened May 20, 2024, a copy of which shall be **ATTACHED** to the original Minutes of this meeting; with the contract expiring June 30, 2025.

BE IT FURTHER RESOLVED, That the award is **CONTINGENT** upon the contractor's submission of properly executed bid and proposal documents, including insurance certificates and all other specified requirements

PURCHASE ORDER

No. 2025-00000027
 DATE: 07/10/2024
 PAGE: 1 of 1
 FOB DESTINATION

Ship To
 CITY OF TROY
 Water
 4693 ROCHESTER ROAD
 TROY, MI 48085

Bill To
 CITY OF TROY
 Water
 4693 ROCHESTER ROAD
 TROY, MI 48085

EXPIRATION DATE
 06/30/2025
COUNCIL RESOLUTION
 2024-06-078-J-4b
INSTRUCTIONS
 Return to Department

VENDOR NO. 126537

Vendor
 CORE & MAIN LP
 PO BOX 28330
 ST LOUIS, MO 63146

QUANTITIES ARE ESTIMATED AND WILL BE ORDERED AS NEEDED

QUANTITY	UNIT	DESCRIPTION	UNIT COST	TOTAL COST
1	Lump Sum	1 Year Requirement - Water System Materials Total price is based on estimated purchases. Items will be ordered on an as needed basis. Items Include: Proposal #1 Curb Box Items - Minneapolis Pattern Thread; Proposal #2 Water Service Parts;	242,065.0000	\$242,065.00
1	Each	Repair Clamps & Stainless Steel Saddles - 50% List Discount	0.0000	\$0.00
1	Each	Proposal #3 - Priced per bid ITB-COT 23-19 Ford Meter Box Brass Saddles - 45% List Discount	0.0000	\$0.00
1	Each	Proposal #4 & #5 Priced per bid ITB-COT 23-19 Ford Meter Box Mueller Fire Hydrant & Valve Parts - 25% & 4% List Discount	0.0000	\$0.00
		Proposal #6 - Priced per bid ITB-COT 23-19 Mueller		

Entered By: Nellie Bert

\$242,065.00

Special Instructions:

CITY COUNCIL AWARD DATE:6-10-2024. Contract for Water System Materials in accordance with the specifications and completion date of ITB-COT 24-06. CERTIFICATE OF INSURANCE and ENDORSEMENTS and BONDS shall be on file through contract completion.

TERMS & CONDITIONS

1. Purchases of Municipalities are exempt from State Sales and Federal Excise Taxes.
2. Prior to acceptance, vendor agrees to provide City with information under the Right-to-Know Law, P.A. 1986, No. 80, and fully comply with all terms and conditions of the Michigan Occupational Safety and Health Act, MCL 408.1001, et seq. including vendor shall provide City with an "MSDS". Vendor also agrees to be responsible for all required labeling.
3. In cases of emergency/disaster, the City can purchase up to six(6) times the order amount for a period of six(6) months at the price contained in the contract.
4. Purchase Orders are signed electronically based upon computer generated "on-line" authorized approvals. Authentic signatures are on file in the City of Troy Purchasing Department.

NOTICE: The City could put the vendor on notice that vendors will be held financially responsible for any claims or awards made against the City as a result of the vendor's action. If the City has to defend the initial lawsuit, the City will bring in the vendor as a co-defendant or sue the vendor, either as the result of settling a claim or the conclusion of the lawsuit.

I HEREBY CERTIFY THAT THIS ORDER IS PROPERLY AUTHORIZED AND APPROVED.

Nellie Bert

CITY OF TROY
 BID TABULATION
 WATER SYSTEM MATERIALS

Vendor Name:	Etna Supply	Core & Main LP	Ferguson Water Works
City:	Grand Rapids, MI	Shelby Twp., MI	Warren, MI

PROPOSAL: MISCELLANEOUS WATER SYSTEM MATERIALS

ITEM #1: CURB BOX ITEMS - MINNEAPOLIS PATTERN - THREAD ON

Line #	Est Qty	Description	Unit Price	Total	Unit Price	Total	Unit Price	Total
1.	300	1" Curb Box Mueller extension curb box w/39" stationary rod #82866 Mueller #10312-99000	\$37.00	\$11,100.00	\$47.35	\$14,205.00	\$58.00	\$17,400.00
2.	25	1 1/2" Curb Box Mueller #10304-99000 2 piece lid, 2" top pipe, 3" bottom tap, 66" extension AY McDonald #5624 2 piece lid, 2" top pipe, 3" bottom tap, 5 1/2" or 66" extended	\$96.00	\$2,400.00	\$93.60	\$2,340.00	\$100.00	\$2,500.00
3.	25	2" Curb Box Mueller #10304-99002 2 piece lid, 2" top pipe, 3 1/2" bottom tap, 66" extension AY McDonald #5625 2 piece lid, 2" top pipe, 3 1/2" bottom tap, 5 1/2" or 66" extended	\$96.00	\$2,400.00	\$93.60	\$2,340.00	\$100.00	\$2,500.00
TOTAL LINE ITEM #1:			\$15,900.00		\$18,885.00		\$22,400.00	
Manufacturer/Model #			Mueller/Listed Model		Mueller/Listed Model		Mueller	

ITEM #2: WATER SERVICE PARTS

Line #	Est Qty	Description	Unit Price	Total	Unit Price	Total	Unit Price	Total
Corporation Stops								
1.	100	1" Corporation Stop with nut Mueller B25000 or approved alternate	\$69.70	\$6,970.00	\$65.09	\$6,509.00	\$68.00	\$6,800.00
2.	100	1 1/2" Corporation Stop with nut Mueller B25000 or approved alternate	\$166.10	\$16,610.00	\$154.10	\$15,410.00	\$161.00	\$16,100.00
3.	100	2" Corporation Stop with nut Mueller B25000 or approved alternate	\$290.00	\$29,000.00	\$269.18	\$26,918.00	\$282.00	\$28,200.00
TOTAL			\$52,580.00		\$48,837.00		\$51,100.00	
Manufacturer/Model #			Mueller/Listed Model		Mueller		Ford	

Brass Fittings

4.	100	1" x 3/4" CCU or 3-part Unions H-15400N Mueller or approved alternate	\$29.50	\$2,950.00	\$26.96	\$2,696.00	\$28.00	\$2,800.00
5.	100	1" CCU or 3-part Unions H-15400N Mueller or approved alternate	\$34.80	\$3,480.00	\$31.87	\$3,187.00	\$33.00	\$3,300.00
6.	100	1-1/2" CCU or 3-part Unions H-15400 Mueller or approved alternate	\$105.35	\$10,535.00	\$95.66	\$9,566.00	\$100.00	\$10,000.00
7.	100	2" CCU or 3-Part Unions H- 15400N Mueller or approved alternate	\$171.90	\$17,190.00	\$156.10	\$15,610.00	\$164.00	\$16,400.00
TOTAL			\$34,155.00		\$31,059.00		\$32,500.00	

Couplings

8.	25	3/4" x 1" PBC or Piggy Back Coupling H-15062 Mueller or approved alternate	\$29.20	\$730.00	\$21.60	\$540.00	\$22.00	\$550.00
TOTAL			\$730.00		\$540.00		\$550.00	
Manufacturer/Model #			Mueller/Listed Model		Ay McDonald		Ford	

CITY OF TROY
 BID TABULATION
 WATER SYSTEM MATERIALS

Vendor Name:		Etna Supply	Core & Main LP	Ferguson Water Works				
City:		Grand Rapids, MI	Shelby Twp., MI	Warren, MI				
Curb Stops								
9.	100	1" CBS or Curb Stops Ford Z22 444M-NL or approved alternate	\$118.15	\$11,815.00	\$114.91	\$11,491.00	\$117.00	\$11,700.00
10.	100	1 1/2" CBS or Curb Stops Mueller B-25154N or approved alternate	\$279.60	\$27,960.00	\$250.80	\$25,080.00	\$263.00	\$26,300.00
11.	100	2" CBS or Curb Stops Mueller B-25154N or approved alternate.	\$452.25	\$45,225.00	\$405.76	\$40,576.00	\$425.00	\$42,500.00
TOTAL			\$85,000.00		\$77,147.00		\$80,500.00	
Manufacturer/Model #		Mueller/Listed Model	Ay McDonald		Ford			
Brass Bends								
12.	100	1 1/2"- 45 Degree Brass Bend Mueller H-15063N or approved alternate	\$103.10	\$10,310.00	\$100.49	\$10,049.00	\$98.00	\$9,800.00
13.	100	2"- 45 Degree Brass Bend Mueller H-15063N or approved alternate	\$190.50	\$19,050.00	\$185.71	\$18,571.00	\$181.00	\$18,100.00
14.	100	1"- 90 Degree Brass Bend Mueller H-15068N or approved alternate	\$37.25	\$3,725.00	\$36.35	\$3,635.00	\$36.00	\$3,600.00
15.	100	1 1/2" - 90 Degree Brass Bend Mueller H-15068N or approved alternate	\$119.10	\$11,910.00	\$116.13	\$11,613.00	\$113.00	\$11,300.00
16.	100	2" - 90 Degree Brass Bend Mueller H-15068N or approved alternate	\$222.90	\$22,290.00	\$217.29	\$21,729.00	\$212.00	\$21,200.00
TOTAL			\$67,285.00		\$65,597.00		\$64,000.00	
Manufacturer/Model #		Mueller/Listed Model	Mueller		Ford			
TOTAL LINE ITEM #2:			\$239,750.00		\$223,180.00		\$228,650.00	
GRAND TOTAL ALL ITEMS:			\$255,650.00		\$242,065.00		\$251,050.00	
ITEM #3: <u>Stainless Steel Repair Clamps</u> Single & Double Band, Solid and CC tap connections 1", 1 1/2", 2", Sizes 2" through 24" (US Manufactured, no iron lugs or bolts).								
Discount:		15%	50%	50%				
Manufacturer:		Mueller	Romac (SS Series)	Ford Meter Box				
Parts Price List:		Repair Clamps	Romac Price List	off				
Date:		Time of Purchase	1/10/2011	1/1/2023				
ITEM #4: <u>Brass Saddle Brass Tap Saddles</u>, 100% lead free, no steel bands, cc taps 3/4", 1", 1 1/2", 2", size ranges 4" through 24" (US Manufactured).								
Discount:		15%	45%	45%				
Manufacturer:		Mueller	Mueller	Ford Meter Box				
Parts Price List:		Brass Saddles	Mueller Service Saddles					
Date:		Time of Purchase	4/1/2019	1/1/2023				
ITEM #5: <u>Stainless Steel Saddle</u> Stainless steel tap saddles (compatible with plastic, brass or stainless-steel pipe), 100% lead free, stainless steel bands, cc taps 3/4", 1", 1-1/2", 2", size ranges 4" through 24" (US Manufactured)								
Discount:		15%	50%	45%				
Manufacturer:		Mueller	Powerseal	Ford Meter Box				
Parts Price List:		SS Saddles	Powerseal Saddles					
Date:		Time of Purchase	N/A	1/1/2023				
ITEM #6: <u>Mueller Complete Fire Hydrant & Valve Parts</u>								
Discount on Mueller complete fire hydrants:		0%	20%	25%				
Discount:		15%	4%	25%				
Manufacturer:		Mueller	Mueller	Mueller				
Parts Price List:		Hydrant Parts	Mueller Blue					
Date:		Time of Purchase	2/9/2012	2/1/2012				

CITY OF TROY
 BID TABULATION
 WATER SYSTEM MATERIALS

Vendor Name:	Etna Supply	Core & Main LP	Ferguson Water Works
City:	Grand Rapids, MI	Shelby Twp., MI	Warren, MI
Delivery:			
Company's minimum shipment:	0	N/A	NA
Days within phone request:	36 Week Lead Time	3 - 14 Days	300 Days
Hours of Operation:	7AM - 5PM	7:30 AM - 4:00 PM	7:00 - 5:00
24 Hour Phone No.:	(616) 245-4373	(586) 785-8851	(810) 691-2823
Contact Person:	Dalton Potgeter	Angela Caponi	David M Hobson
Descriptive Literature Provided: Y or N	N	Y	N
Payment Terms:	Net 30	Net 30	Net 30
Warranty:	Manufacturer	Manufacturer's Limited	Manufactures Warranty
		3-4 weeks on curb boxes/ 17-19 weeks for most AY brass	1 - 210 days
Delivery:	36 Week Lead Time	All "water service parts" quoted are AY McDonald with the exception of items #'s 12 -16 which are	None listed
Exceptions:	N/A		
Allow bid to be broken up: Y or N	N	Y	Y
Acknowledgement: Y or N	Y	Y	Y
Forms: Y or N	Y	Y	Y

ATTEST:

(*Bid Opening conducted via a Zoom Meeting)

Theresa Shepard

Andrew Chambliss

Nellie Bert

Bryan Pompa

Emily Frontera

Purchasing Manager



**CITY OF TROY
BID PROPOSAL**

The undersigned proposes to furnish **ONE (1) YEAR REQUIREMENTS OF WATER SYSTEM MATERIALS**, in accordance with the attached specifications, which are to be considered an integral part of this proposal at the following prices:

COMPANY NAME: Corc : Main LP

PROPOSAL: Miscellaneous Water System Materials

Item 1: Curb Box Items Minneapolis Pattern – Thread on

Line #	Est Quantity	Description	Unit Price	Total
1.	300	1" Curb Box Mueller extension curb box w/39" stationary rod #82866 Mueller #10312-99000	\$ 47.35	\$ 14,205.00
2.	25	1 1/2" Curb Box Mueller #10304-99000 2-piece lid, 2" top pipe, 3" bottom tap, 66" extension AY McDonald #5624 2-piece lid, 2" top pipe, 3" bottom tap, 5 1/2 or 66" extended	\$ 93.60	\$ 2,340.00
3.	25	2" Curb Box Mueller #10304-99002 2-piece lid, 2" top pipe, 3 1/2" bottom tap, 66" extension AY McDonald #5625 2-piece lid, 2" top pipe, 3 1/2" bottom tap, 5 1/2 or 66" extended	\$ 93.60	\$ 2,340.00

Manufacturer: Mueller Model: listed model

Item 2: Water Service Parts

Line #	Est Quantity	Description	Unit Price	Total
Corporation Stops				
1.	100	1" Corporation Stop with nut Mueller B25000 or approved alternate	\$ 65.09	\$ 6509.00
2.	100	1 1/2" Corporation Stop with nut Muller B25000 or approved alternate	\$ 154.10	\$ 15,410.00
3.	100	2" Corporation Stop with nut Mueller B25000 or approved alternate	\$ 269.18	\$ 26,918.00

Item 2: Water Service Parts – cont.

Line #	Est Quantity	Description	Unit Price	Total
Brass Fittings AY model 74758				
4.	100	1" x 3/4" CCU or 3-part Union H-15400N Mueller or approved alternate	\$ 26.96	\$ 2696.00
5.	100	1" CCU or 3-part Unions H-15400N Mueller or approved alternate	\$ 31.87	\$ 3187.00
6.	100	1 1/2" CCU or 3-part Unions H-15400 Mueller or approved alternate	\$ 95.66	\$ 9566.00
7.	100	2" CCU or 3-part Unions H-15400N Mueller or approved alternate	\$ 156.10	\$ 15610.00
Couplings AY model 74755				
8.	25	3/4" x 1" PBC or Piggy Back Coupling H-15062 Mueller or approved alternate	\$ 21.60	\$ 2160.00
Curb Stops AY model 76104				
9.	100	1" CBS or Curb Stops Ford Z22 444M-NL or approved alternate	\$ 114.91	\$ 11491.00
10.	100	1 1/2" CBS or Curb Stops Mueller B-25154N or approved alternate	\$ 250.80	\$ 25080.00
11.	100	2" CBS or Curb Stops Mueller B-25154N or approved alternate	\$ 405.76	\$ 40576.00
Brass Bends listed Mueller model				
12.	100	1 1/2"- 45 Degree Brass Bend Mueller H-15063N or approved alternate	\$ 100.49	\$ 10049.00
13.	100	2"- 45 Degree Brass Bend Mueller H-15063N or approved alternate	\$ 185.71	\$ 18571.00
14.	100	1"- 90 Degree Brass Bend Mueller H-15068N or approved alternate	\$ 36.35	\$ 3635.00
15.	100	1 1/2"- 90 Degree Brass Bend Mueller H-15068N or approved alternate	\$ 116.13	\$ 11613.00
16.	100	2"- 90 Degree Brass Bend Mueller H-15068N or approved alternate	\$ 217.29	\$ 21729.00

Manufacturer: AY McDonald/Mueller Model: _____

COMPANY NAME: Core + Main LP

Item 3: Stainless Steel Repair Clamps Single and Double Band, Solid and CC tap connections 1", 1-1/2", 2", Sizes 2" through 24" (US Manufactured, no iron lugs or bolts)

A discount of 50 % will be given on all parts Romac (SS series)
Manufacturer
Parts Price List Romac Price list dated 1/10/22 will be used.

A published list or company pricing sheet will be accepted. Price lists shall be submitted with the bid or available on-line at attached.

Item 4: Brass Saddle Brass tap saddles, 100% lead free, no steel bands, cc taps 3/4", 1", 1-1/2", 2", size ranges 4" through 24" (US Manufactured)

A discount of 45 % will be given on all parts Mueller
Manufacturer
Parts Price List Mueller Service Saddles dated 4/11/2019 will be used.

A published list or company pricing sheet will be accepted. Price lists shall be submitted with the bid or available on-line at muellercompany.com/water-works/

Item 5: Stainless Steel Saddle Stainless steel tap saddles (compatible with plastic, brass or stainless-steel pipe), 100% lead free, stainless steel bands, cc taps 3/4", 1", 1-1/2", 2", size ranges 4" through 24" (US Manufactured)

A discount of 50 % will be given on all parts Powerseal
Manufacturer
Parts Price List Powerseal Saddles dated N/A will be used.

A published list or company pricing sheet will be accepted. Price lists shall be submitted with the bid or available on-line at powerseal.com/products

Item 6: Mueller Complete Fire Hydrants & Valve Parts

A discount of 20 % will be given on all Mueller complete fire hydrants
A discount of 4 % will be given on all parts Mueller
Manufacturer
Parts Price List Mueller Blue Price Sheet dated 2/9/2012 will be used.

A published list or company pricing sheet will be accepted. Price lists shall be submitted with the bid or available on-line at muellercompany.com/water-works/

UNIT PRICES:

Unit prices prevail; the City of Troy Purchasing Department will correct all mathematical errors.

ESTIMATED QUANTITIES:

Quantities stated are estimated and are not guaranteed. Quantities stated are for award purposes only and based upon past usage.

COMPANY NAME: Core + Main LP

DELIVERY:

Your company's minimum shipment: N/A

Within 3-4 days once material is in days of a phone request.

All items will be F.O.B. delivered freight paid to the City of Troy Department of Public Works 4693 Rochester Rd., Troy, MI 48085. Items will be ordered as needed via a phone or fax request by the City of Troy Public Works Department. Please call **Teresa Shepard** prior to delivery at **(248) 524-3376**.

CONTACT INFORMATION:

Hours of operation: 7:30 AM - 4:00 pm 24 Hour Phone No. 586-785-8851

Contact Person: Angela Caponi Title municipal sales

AWARD:

Each proposal will be considered as a separate bid. The City of Troy reserves the right to combine proposals if deemed in the City's best interest to do so. Also, The City reserves the right to reject low bids which have major deviations from specifications, and to award a higher bid with only minor deviations. If your company's minimum shipment requirement is greater than \$500.00, your bid will not be considered for an award.

LOCAL PREFERENCE:

The City of Troy reserves the right to award a contract to a local business, one which pays City of Troy taxes (real and/or personal), if the bid of a local vendor is within 5% of the lowest responsive and responsible non-local bidder, then the local vendor is given one chance to match the low bid.

DOWNPAYMENTS AND PREPAYMENTS:

Any proposal submitted which requires a down payment or prepayment of any kind prior to delivery and acceptance of the items as being in conformance with specifications will not be considered for award.

APPROVED ALTERNATES:

The Public Works Director or his designated representative will review material submitted for consideration as an approved alternate. The decision made as to acceptability will be deemed in the City of Troy's best interest and will be final.

DESCRIPTIVE LITERATURE:

Please attach descriptive or pertinent literature relevant to your company's bid proposal at the time of bid submission. It is attached and marked _____ for identification.

ADDITIONAL INFORMATION:

For additional general information or questions about this project, please contact **Teresa Shepard**, at **(248) 524-3376** between the hours of 8:00 a.m. and 4:30 p.m.

CONTRACT FORMS:

Bidders should complete and sign the Legal Status of Bidder, Non-Collusion Affidavit, Certification regarding Debarment, the Certification regarding "Iran Linked Business" and the Familial Disclosure Forms and return with your bid proposal.

COMPANY NAME: Core + Main LP

SIGNATURE PAGE

PRICES:

All bidders are held to bid prices for sixty (60) days or bid award, whichever comes first, except the successful bidder(s) whose prices shall remain firm for the entire contract period. The contract shall commence on the date of award or **July 1, 2024** whichever is later and expire one (1) calendar year later.

SIGNATURE OF AUTHORIZED COMPANY REPRESENTATIVE: Thomas Fisher

NOTE: The undersigned has checked carefully the bid figures and understands that he/she shall be responsible for any error or omission in this bid offer and is in receipt of all addenda as issued.

TAX ID: 03-0550887

COMPANY Core & Main LP

ADDRESS 6575 23 Mile Rd. CITY Shelby Township STATE MI ZIP 48316

PHONE NUMBER (586)323-8800 FAX NUMBER (586)323-8812

COMPANY REPRESENTATIVE'S NAME: Thomas Fisher

SIGNATURE OF AUTHORIZED COMPANY REPRESENTATIVE: Thomas Fisher (Print)

PAYMENT TERMS: Net 30 WARRANTY: Manufacturer's limited warranty

DELIVERY: stock to 3-4 weeks on curb boxes
stock to 17-19 weeks for most AY brass E-MAIL: angela.caponi@coreandmain.com

EXCEPTIONS:

Any exceptions, substitutions, deviations, etc., from the City specifications and this proposal must be stated below. The reason(s) for the exceptions, substitutions, and/or deviations are an integral part of this bid proposal offer: All "water service parts" quoted are AY McDonald with the exception of item #'s 12-16, which are Mueller

Check this box if your bid is not to be broken up

ACKNOWLEDGEMENT:

I, Thomas Fisher, certify that I have read the **Instructions to Bidders** (2 Pages) and that the bid proposal documents contained herein were obtained directly from the City's Purchasing Department or MITN Purchasing Group website, www.bidnetdirect.com/city-of-troy-mi and is an official copy of the Authorized Version.

SIGNATURE OF AUTHORIZED COMPANY REPRESENTATIVE: Thomas Fisher

NOTE: The City of Troy, at their discretion, may require the bidder to supply a Financial Report from an impartial Financial Credit Reporting Service before award of contract at no cost to the City.

IMPORTANT: All City of Troy purchases require a **SAFETY DATA SHEET**, where applicable, in compliance with the **MIOSHA "Right to Know" Law**. Please include a copy of any relevant SDS at the time of bid submission.

U.S. CURRENCY: All figures quoted are to be in U.S. Funds.



Legal Status of Bidder:

The Bidder shall fill out the appropriate form and strike out the other two:

~~A corporation duly organized and doing business under the laws of the State of _____
for whom _____ bearing the office title of _____,
whose signature is affixed to this proposal, is duly authorized to execute contracts.~~

A partnership, all members of which, with addresses, is:

- | | |
|--|--|
| 1. Core: Main Intermediate
GP-LLC - General Partner
(Delaware LLC) | Address for all partners is:
1830 Craig Park Ct.
St. Louis, MO 63146 |
| 2. Core: Main Mideo LLC
Limited Partner (Delaware LLC) | |

~~AN INDIVIDUAL, WHOSE SIGNATURE IS AFFIXED TO THE PROPOSAL:~~



CITY OF TROY
OAKLAND COUNTY, MICHIGAN
NON-COLLUSION AFFIDAVIT

TO WHOM IT MAY CONCERN:

Thomas B Fisher, being duly sworn deposed, says that he/she
(Print Full Name)

is DISTRICT MANAGER. The party making the foregoing proposal or bid,
(State Official Capacity in Firm)

that such bid is genuine and not collusion or sham; that said bidder has not colluded, conspired, connived, or agree, directly or indirectly, with any bidder or person, to put in a sham bid or to refrain from bidding and has not in any manner directly or indirectly sought by agreement or collusion, or communication or conference, with any person to fix the bid price or affiant or any other bidder, or to fix any overhead, profit, or cost element of said bid price, or that of any other bidder, or to secure the advantage against the City of Troy or any person interested in the proposed contract; and that all statements contained in said proposal or bid are true.

Thomas B Fisher
SIGNATURE OF PERSON SUBMITTING BID

[Signature]
NOTARY'S SIGNATURE

Subscribed and sworn to before me this 15 day of may, 2024

in and for macomb County.

My commission expires:

03/20/2025

RICHARD ALAN BREAUX
Notary Public - State of Michigan
County of Macomb
My Commission Expires Mar 20, 2025
Acting in the County of macomb





**CERTIFICATION REGARDING
DEBARMENT, SUSPENSION, AND OTHER RESPONSIBILITY MATTERS**

The prospective participant certifies, to the best of its knowledge and belief, that it and its principals:

1. Are not presently debarred, suspended, proposed for debarment, declared ineligible, or voluntarily excluded from participation in transactions under any non-procurement programs by any federal, state or local agency.
2. Have not, within the three-year period preceding, had one or more public transactions (federal, state, or local) terminated for cause or default; and
3. Are not presently indicted or otherwise criminally or civilly charged by a government entity (federal, state, or local) and have not, within the three-year period preceding the proposal, been convicted of or had a civil judgment rendered against it:
 - a. For the commission of fraud or a criminal offense in connection with obtaining, attempting to obtain, or performing a public transaction (federal, state, or local), or a procurement contract under such a public transaction;
 - b. For the violation of federal, or state antitrust statutes, including those proscribing price fixing between competitors, the allocation of customers between competitors, or bid rigging; or
 - c. For the commission of embezzlement, theft, forgery, bribery, falsification or destruction of records, making false statements, or receiving stolen property.

I understand that a false statement on this certification may be grounds for the rejection of this proposal or the termination of the award. In addition, the general grant of this authority exists within the City's Charter, Chapter 12, Section 12.2- Contracts.

I am able to certify to the above statements.

Core & Main LP

Name of Agency/Company/Firm *(Please Print)*

Thomas Fisher-Michigan District Manager

Name and title of authorized representative *(Please Print)*

Thomas Fisher

5/15/24

Signature of authorized representative

Date

I am unable to certify to the above statements. Attached is my explanation.



**VENDOR CERTIFICATION
THAT IT IS NOT AN
"IRAN LINKED BUSINESS"**

Pursuant to Michigan law, (the Iran Economic Sanctions Act, 2012 PA 517, MCL 129.311 et seq.), before accepting any bid or proposal, or entering into any contract for goods or services with any prospective Vendor, the Vendor must first certify that it is not an "IRAN LINKED BUSINESS", as defined by law.

Vendor	
Legal Name	Core & Main LP
Street Address	6575 23 Mile Rd.
City	Shelby Township
State, Zip	Michigan, 48316
Corporate I.D. Number/State	03-0550887
Taxpayer I.D. #	

The undersigned, with: 1.) full knowledge of all of Vendors business activities, 2.) full knowledge of the requirements and possible penalties under the law MCL 129.311 et seq. and 3.) the full and complete authority to make this certification on behalf of the Vendor, by his/her signature below, certifies that: the Vendor is NOT an "IRAN LINKED BUSINESS" as require by MCL 129.311 et seq., and as such that Vendor is legally eligible to submit a bid and be considered for a possible contract to supply goods and/or services to the City of Troy.

Signature of Vendor's Authorized Agent: *Thomas Fisher*

Printed Name of Vendor's Authorized Agent: Thomas Fisher

Witness Signature: *Angela Caponi*

Printed Name of Witness: Angela Caponi



Proposer's Sworn and Notarized Familial Disclosure
(to be provided by the Proposer)

The undersigned, the owner or authorized officer of CORE AND MASON LP (the "Proposer"), pursuant to the familial disclosure requirement provided in the Request for Proposal, hereby represent and warrant, except as provided below, that no familial relationships exist between the owner(s) or any employees of CORE AND MASON LP and any member of the City of Troy City Council or City of Troy management.

List any Familial Relationships:

None

BIDDER:

Thomas B Fisher
By: Thomas B Fisher
Its: DISTRICT MANAGER

STATE OF MICHIGAN

)ss.

COUNTY OF MACOMB)

This instrument was acknowledged before me on the 15 day of MAY, 2024, by

Thomas B Fisher

Richard Alan Breaux
Richard Alan Breaux

RICHARD ALAN BREAUX
Notary Public - State of Michigan
County of Macomb
My Commission Expires Mar 20, 2025
Acting in the County of MACOMB

STYLE SS1 (ONE SECTION) NORMAL RANGE .40"



MATERIAL SPECIFICATIONS

- SHELLS AND LUGS:** Stainless steel per ASTM A240, type 304.
- BOLTS:** UNC rolled thread, type 304 stainless steel.
- NUTS:** Stainless steel per ASTM A194, type 304. Coated to prevent galling.
- WASHERS:** Stainless steel, type 304 and plastic lubricating washers.
- GASKETS:** SBR per ASTM D2000 MAA 610. Compounded for water and sewer service. Other compounds available on request.

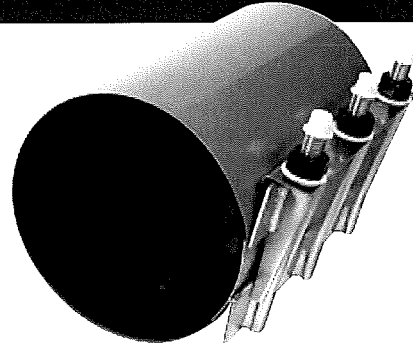

SS1-7.00 x 10" REPAIR CLAMP



NSF61 certified upon request.

MEETS
AWWA C230

REPAIR CLAMPS

NOM. PIPE SIZE	O.D. RANGE (inches)	CATALOG NUMBER	LENGTH / WEIGHT							
			6"	8"	10"	12"	16"	20"	24"	30"
2"-2 1/4"	2.35 - 2.63	SS1 - 2.63 x length	\$151.70	\$206.83	\$287.80	\$344.07	\$370.48	\$418.28	N/A	N/A
	2.62 - 2.87	SS1 - 2.87 x length	4#	4#	5#	5#	8#	11#		
2 1/2"	2.75 - 3.00	SS1 - 3.00 x length	157.68	215.00	298.20	352.11	381.50	461.95	N/A	N/A
	2.87 - 3.12	SS1 - 3.12 x length	4#	4#	5#	5#	8#	11#		
3"	3.45 - 3.70	SS1 - 3.70 x length	182.58	225.66	311.85	365.45	412.60	529.39	N/A	N/A
	3.75 - 4.00	SS1 - 4.00 x length	4#	5#	5#	6#	9#	12#		
3 1/2"	3.95 - 4.20	SS1 - 4.20 x length	191.81	239.58	325.09	384.13	429.94	559.34	702.48	N/A
			5#	5#	6#	7#	9#	13#	15#	
4"	4.45 - 4.85	SS1 - 4.85 x length	203.96	254.51	346.79	404.28	449.52	681.73	914.53	1,115.67
	4.74 - 5.14	SS1 - 5.14 x length								
	4.95 - 5.35	SS1 - 5.35 x length								
	5.20 - 5.60	SS1 - 5.60 x length								
6"	5.95 - 6.35	SS1 - 6.35 x length	253.88	304.56	412.60	486.30	536.35	809.04	1,018.10	1,325.52
	6.60 - 7.00	SS1 - 7.00 x length								
	6.84 - 7.24	SS1 - 7.24 x length								
	7.06 - 7.46	SS1 - 7.46 x length								
7.40 - 7.80	SS1 - 7.80 x length									
8"	7.95 - 8.35	SS1 - 8.35 x length	298.25	356.88	472.71	572.74	654.49	927.21	1,154.43	1,521.99
	8.60 - 9.00	SS1 - 9.00 x length								
	9.00 - 9.40	SS1 - 9.40 x length								
	9.30 - 9.70	SS1 - 9.70 x length								
10"	9.95 - 10.35	SS1-10.35 x length	391.24	475.54	625.61	746.14	857.31	1,144.74	1,422.66	1,946.27
	10.70 - 11.10	SS1-11.10 x length								
	11.04 - 11.44	SS1-11.44 x length								
	11.40 - 11.80	SS1-11.80 x length								
	11.60 - 12.00	SS1-12.00 x length								
11.85 - 12.25	SS1-12.25 x length									
12"	12.10 - 12.50	SS1-12.50 x length	456.68	539.91	716.00	864.72	977.80	1,357.91	1,612.72	2,301.88
	12.70 - 13.10	SS1-13.10 x length								
	13.15 - 13.55	SS1-13.55 x length								
	13.60 - 14.00	SS1-14.00 x length								
14.10 - 14.50	SS1-14.50 x length									

NUMBER OF BOLTS PER CLAMP LENGTH

O.D. RANGE	6"	8"	10"	12"	16"	20"	24"	30"
2.35 - 9.99	2	2	3	3	4	5	6	8
10.00 - 14.50	2	3	3	4	5	7	8	10

1.25" range

FOR TAPPED SS1 SEE PAGE 2-14.
FOR SEWER O.D.S SEE PAGE 7-7.

For higher working pressures, clamp length should equal or exceed diameter of pipe. Some sizes and lengths not listed are available on request. Clamps are not to be used for joining plain end pipe.

TO ORDER: Specify catalog number x length of clamp desired.

EXAMPLE: For a one-section clamp for pipe with an O.D. between 6.60 and 7.00 and clamp length of 10", order **SS1 - 7.00 x 10"**



STYLE SS2 (TWO SECTION) WIDER RANGE .80"

MATERIAL SPECIFICATIONS

SHELLS AND LUGS: Stainless steel per ASTM A240, type 304.

BOLTS: UNC rolled thread, type 304 stainless steel.

NUTS: Stainless steel per ASTM A194, type 304. Coated to prevent galling.

WASHERS: Stainless steel, type 304 and plastic lubricating washers.

GASKETS: SBR per ASTM D2000 MAA 610. Compounded for water and sewer service. Other compounds available on request.

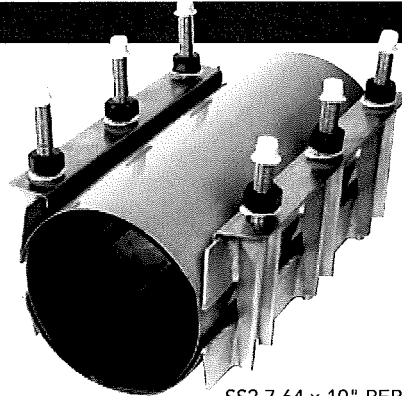

SS2-7.64 x 10" REPAIR CLAMP



NSF61 certified upon request.

MEETS
AWWA C230

NOM. PIPE SIZE	O.D. RANGE (inches)	CATALOG NUMBER	LENGTH / WEIGHT						
			8"	10"	12"	16"	20"	24"	30"
4"	4.47 - 5.27 4.77 - 5.57 5.20 - 6.00	SS2 - 5.27 x length SS2 - 5.57 x length SS2 - 6.00 x length ¹	\$401.58 9#	\$527.46 12#	\$624.61 13#	\$746.74 17#	\$1,000.00 25#	\$1,278.95 30#	N/A
6"	6.57 - 7.37 6.84 - 7.64 7.20 - 8.00	SS2 - 7.37 x length SS2 - 7.64 x length SS2 - 8.00 x length ¹	461.64 11#	593.91 15#	676.47 17#	873.41 22#	1,192.21 28#	1,567.50 34#	1,687.43 43#
8"	8.59 - 9.39 8.99 - 9.79 9.20 - 10.00	SS2 - 9.39 x length SS2 - 9.79 x length SS2-10.00 x length ¹	528.39 12#	659.41 17#	768.53 19#	1,000.00 24#	1,353.76 30#	1,790.34 36#	1,903.29 47#
10"	10.70 - 11.50 11.04 - 11.84 11.40 - 12.20	SS2-11.50 x length SS2-11.84 x length SS2-12.20 x length	534.20 15#	864.67 18#	1,186.80 23#	1,244.54 32#	1,659.42 41#	2,206.06 47#	2,486.51 59#
12"	12.70 - 13.50 13.15 - 13.95 13.50 - 14.30 13.71 - 14.51	SS2-13.50 x length SS2-13.95 x length SS2-14.30 x length SS2-14.51 x length	684.65 16#	991.29 19#	1,347.42 25#	1,423.61 33#	1,921.44 41#	2,450.73 50#	2,800.18 61#
14"	15.00 - 15.80 15.95 - 16.75	SS2-15.80 x length SS2-16.75 x length	981.57 18#	1,325.52 21#	1,712.44 27#	1,908.76 33#	2,584.60 43#	3,057.52 50#	3,219.18 64#

¹ Recommended for use on CL200 ACRB

NUMBER OF BOLTS PER CLAMP LENGTH							
O.D. RANGE	8"	10"	12"	16"	20"	24"	30"
4.47 - 9.99	4	6	6	8	10	12	16
10.00 - 16.75	6	6	8	10	14	16	20

FOR TAPPED SS2 SEE PAGE 2-14.

FOR SEWER O.D.S SEE PAGE 7-8.

For higher working pressures, clamp length should equal or exceed diameter of pipe. Some sizes and lengths not listed are available on request. Clamps are not to be used for joining plain end pipe.

REPAIR CLAMPS

TO ORDER: Specify catalog number x length of clamp desired.

EXAMPLE: For a two-section clamp for pipe with an O.D. between 6.84 and 7.64 and clamp length of 10", order **SS2 - 7.64 x 10"**

STYLE SS3 (THREE SECTION)

WIDEST RANGE 1.20"



REPAIR CLAMPS

MATERIAL SPECIFICATIONS

SHELLS AND LUGS: Stainless steel per ASTM A240, type 304.

BOLTS: UNC rolled thread, type 304 stainless steel.

NUTS: Stainless steel per ASTM A194, type 304. Coated to prevent galling.

WASHERS: Stainless steel, type 304 and plastic lubricating washers.

GASKETS: SBR per ASTM D2000 MAA 610. Compounded for water and sewer service. Other compounds available on request.

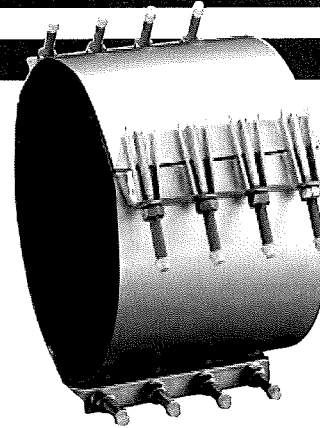

SS3-14.65 x 12" REPAIR CLAMP



NSF61 certified upon request.

MEETS
AWWA C230

O.D. RANGE (inches)	CATALOG NUMBER	LENGTH / WEIGHT							
		8"	10"	12"	16"	20"	24"	30"	36"
11.04-12.24 12.40-13.60	SS3-12.24 x length SS3-13.60 x length	\$817.07 22#	\$1,094.00 27#	\$1,372.99 31#	\$1,851.36 41#	\$2,660.12 53#	\$2,704.96 61#	\$3,104.81 80#	\$4,511.78 94#
13.14-14.34 13.45-14.65	SS3-14.34 x length SS3-14.65 x length	936.13 24#	1,215.43 29#	1,558.71 33#	1,977.14 43#	2,736.54 56#	3,001.95 65#	3,496.18 85#	4,713.66 99#
15.30-16.50 17.10-18.30	SS3-16.50 x length SS3-18.30 x length	1,236.58 25#	1,862.87 30#	1,919.38 35#	2,489.41 45#	3,307.26 59#	3,461.39 72#	5,090.65 89#	5,796.55 103#
18.00-19.20 19.50-20.70	SS3-19.20 x length SS3-20.70 x length	1,396.17 26#	1,907.06 32#	2,027.25 36#	2,538.76 49#	3,441.97 63#	4,255.54 76#	5,389.84 95#	5,981.18 112#
21.60-22.80	SS3-22.80 x length	1,545.49 30#	2,065.73 35#	2,243.00 40#	2,875.89 53#	3,819.48 67#	4,351.73 80#	5,840.30 102#	6,695.71 120#
23.25-24.45	SS3-24.45 x length	2,051.46 33#	2,276.99 38#	2,530.17 43#	3,684.91 56#	4,965.53 71#	5,694.65 84#	7,189.47 109#	8,650.47 129#
25.80-27.00	SS3-27.00 x length	2,557.14 35#	2,708.74 40#	2,825.55 45#	4,493.55 60#	6,111.13 75#	7,036.82 88#	7,954.04 115#	10,605.30 135#

NUMBER OF BOLTS PER CLAMP LENGTH

O.D. RANGE	8"	10"	12"	16"	20"	24"	30"	36"
All Ranges	9	9	12	15	21	24	30	36

FOR TAPPED SS3 SEE PAGE 2-14.

FOR SEWER O.D.S SEE PAGE 7-8.

For higher working pressures, clamp length should equal or exceed diameter of pipe. Some sizes and lengths not listed are available on request. Clamps are not to be used for joining plain end pipe.

TO ORDER: Specify catalog number x length of clamp desired.

EXAMPLE: For a 3-section clamp for pipe with an O.D. between 13.45 and 14.65 and clamp length of 12", order **SS3 - 14.65 x 12"**

TAPS FOR REPAIR CLAMPS

SS1, SS2, SS3, SL1, SL2, CL1, CL2, AND CL3



AVAILABLE IN ALL STYLES

The same design, construction, and installation features as Styles 1, 2, and 3. Tapped outlet is 304 stainless steel, permanently "fused" by GTAW, and fully passivated¹.

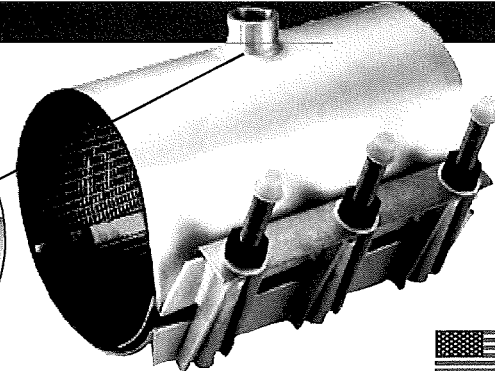
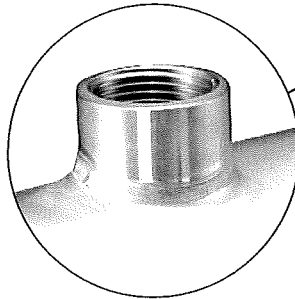
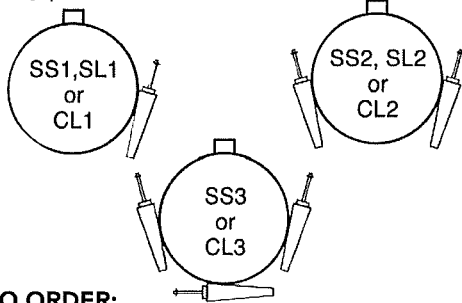

SS1-7.00 x 12 x 3/4" IP TAPPED REPAIR CLAMP



NSF61 certified upon request.

MEETS AWWA C800

TO ORDER:

1. Select size, length, and style of clamp.
2. Select size and type of tapped thread desired from the table below.
3. Add list price for tap to the list price of clamp selected from separate price sheet.
4. **Tapped outlet products are NO CANCEL/NO RETURN items**, please be specific when ordering.

EXAMPLE: SS1-7.00 x 12 x 3/4" IP would be a one-section clamp for pipe with an O.D. between 6.60 and 7.00, a length of 12" and 3/4" iron pipe tap size.

ADD-ON LIST PRICES FOR TAPPED CLAMPS

TAP SIZE	TYPE OF THREAD	MINIMUM PIPE O.D.	MINIMUM CLAMP LENGTH	ADD ON LIST PRICE
1/2" 4	IP	2.38"	6" for 2.38" through 14.65" pipe O.D. 8" for 14.66" through 19.50" pipe O.D.	\$105.14
3/4" or 1"	CC or IP	2.38"	6" ⁵ for 2.38" through 14.65" pipe O.D. 8" ⁵ for 14.66" through 19.50" pipe O.D.	105.14
1 1/4"	CC	3.50"	8" for 3.50" through 8.00" pipe O.D. 10" for 8.01" through 14.65" pipe O.D. 12" for 14.66" through 19.50" pipe O.D.	164.80
1 1/4"	IP	2.88"	8" for 2.88" through 8.00" pipe O.D. 10" for 8.01" through 14.65" pipe O.D. 12" for 14.66" through 19.50" pipe O.D.	164.80
1 1/2"	CC or IP	3.50"	8" for 3.50" through 8.00" pipe O.D. 10" for 8.01" through 14.65" pipe O.D. 12" for 14.66" through 19.50" pipe O.D.	164.80
2"	IP	3.50"	8" for 3.50" through 8.00" pipe O.D. 10" for 8.01" through 14.65" pipe O.D. 12" for 14.66" through 19.50" pipe O.D.	164.80
2"	CC	4.50"	8" for 4.50" through 8.00" pipe O.D. 10" for 8.01" through 14.65" pipe O.D. 12" for 14.66" through 19.50" pipe O.D.	201.78
2 1/2" 2, 4	IP or MIP	6.63"	12" for 6.63" through 14.65" pipe O.D. 16" for 14.66" through 19.50" pipe O.D.	466.05
3" 2, 3, 4	IP or MIP	6.63"	12" for 6.63" through 14.65" pipe O.D. 16" for 14.66" through 19.50" pipe O.D.	466.05

¹ Passivated: Chemically treated after welding to produce a highly corrosion-resistant coating.

² Requires SS2 or SS3

³ 6.63 - 9.99 Taps must be MIP

⁴ Not available with CL clamps.

⁵ CL clamps 8.35 and larger with outlets less than or equal to 1" have a minimum clamp length of 7.5".

Tapped CL1 clamps are available in sizes 3.70 and larger. Contact Romac's Engineering Department for larger sizes.



500 West Big Beaver
 Troy, MI 48084
 troymi.gov

CITY COUNCIL AGENDA ITEM

Date: May 31, 2024

To: Robert J Bruner, Acting City Manager

From: Megan E. Schubert, Assistant City Manager
 Dee Ann Irby, Controller
 Kurt Bovensiep, Public Works Director
 Jason Schmidt, Water & Sewer Operations Manager
 Emily Frontera, Purchasing Manager

Subject: Standard Purchasing Resolution 2 – Award to Low Bidder Meeting Specifications – Water System Materials

History

- The Water and Sewer Division is responsible for new water service installations and maintenance, water main repairs and replacement, and Mueller hydrant repairs and replacement.
- In order to maintain these infrastructure assets, minimum quantities of parts are kept on hand.
- Water System Materials will be purchased on an as needed basis to replenish inventories throughout the year at unit prices as specified and detailed in the bid tabulation.
- The current contract is expiring June 30, 2024.

Purchasing

- On May 20, 2024, a bid opening was conducted as required by the City Charter/Code for one (1) year requirements of Water System Materials.
- The bid was posted on the MITN Purchasing Group website, www.bidnetdirect.com/city-of-troy-mi.
- Three (3) bids were received. Below is a detailed summary of potential vendors.

Companies notified via MITN	337
Troy Companies notified via MITN	6
Troy Companies - Active email Notification	6
Troy Companies - Active Free	0
Companies that viewed the bid	26
Troy Companies that viewed the bid	0

MITN provides a resourceful online platform to streamline the procurement process, reduce costs, and make it easier and more transparent for vendors to do business with the City of Troy.

Active MITN members with a current membership and paying annual dues receive automatic electronic notification which allows instant access to Bids, RFPS and Quote opportunities with the City.

Active MITN non-paying members are responsible to monitor and check the MITN website for opportunities to do business with the City.

Inactive MITN member status can occur when a company does not renew their account upon expiration. Inactive members cannot be notified of solicitations or access any bid information.

- Based upon the bid responses and per the attached bid tabulation; it is in the City’s best interest to award the contract to the overall low bidder as specified.
- Etna indicated that their bid was not to be broken up and quoted a lead time of 36 weeks. Ferguson quoted a lead time of 30 weeks. Core & Main quoted a lead time of 17-19 weeks and has demonstrated a high level of customer service during previous contracts. Therefore, *Core & Main of Shelby Twp., MI* is the overall low bidder meeting specifications and pricing requirements and is being recommended for award.



500 West Big Beaver
 Troy, MI 48084
 troymi.gov

CITY COUNCIL AGENDA ITEM

Financial

Funds are available in the operating budgets for the Water and Sewer Division for the 2025 Fiscal Year. These funds will be expensed primarily from three accounts; Maintenance of Mains 591.537.541.740.010, Maintenance of Service 591.537.542.740.010, and Maintenance of Hydrants 591.537.544.740.010.

Recommendation

City Management recommends awarding a one (1) year contract for Water System Materials, to overall low bidder meeting specifications, *Core & Main of Shelby Twp., MI* for an estimated total cost of \$242,065.00 at unit prices contained in the bid tabulation opened May 20, 2024; to be ordered on an as needed basis.

Core & Main – Shelby Twp., MI	Item #1 Curb Box Items	\$18,885.00
	Item #2 Water Service Parts	\$223,180.00
	Item #3 Romac Repair Clamps	50% List Discount
	Item #4 Mueller Brass Saddles	45% List Discount
	Item #5 Powerseal Stainless Steel Saddles	50% List Discount
	Item #6 Mueller Complete Fire Hydrants Hydrant & Valve Parts	20% List Discount 4% List Discount

Opening Date: 05/20/2024
 Date Reviewed: 05/20/2024

CITY OF TROY
 BID TABULATION
 WATER SYSTEM MATERIALS

ITB-COT 24-06
 Page 1 of 3

Vendor Name:	Etna Supply	Core & Main LP	Ferguson Water Works
City:	Grand Rapids, MI	Shelby Twp., MI	Warren, MI

PROPOSAL: MISCELLANEOUS WATER SYSTEM MATERIALS

ITEM #1: CURB BOX ITEMS - MINNEAPOLIS PATTERN - THREAD ON

Line #	Est Qty	Description	Unit Price	Total	Unit Price	Total	Unit Price	Total
1.	300	1" Curb Box Mueller extension curb box w/39" stationary rod #82866 Mueller #10312-99000	\$37.00	\$11,100.00	\$47.35	\$14,205.00	\$58.00	\$17,400.00
2.	25	1 1/2" Curb Box Mueller #10304-99000 2 piece lid, 2" top pipe, 3" bottom tap, 66" extension AY McDonald #5624 2 piece lid, 2" top pipe, 3" bottom tap, 5 1/2 or 66" extended	\$96.00	\$2,400.00	\$93.60	\$2,340.00	\$100.00	\$2,500.00
3.	25	2" Curb Box Mueller #10304-99002 2 piece lid, 2" top pipe, 3 1/2" bottom tap, 66" extension AY McDonald #5625 2 piece lid, 2" top pipe, 3 1/2" bottom tap, 5 1/2 or 66" extended	\$96.00	\$2,400.00	\$93.60	\$2,340.00	\$100.00	\$2,500.00
TOTAL LINE ITEM #1:			\$15,900.00	\$18,885.00	\$22,400.00			
Manufacturer/Model #			Mueller/Listed Model	Mueller/Listed Model	Mueller			

ITEM #2: WATER SERVICE PARTS

Line #	Est Qty	Description	Unit Price	Total	Unit Price	Total	Unit Price	Total
Corporation Stops								
1.	100	1" Corporation Stop with nut Mueller B25000 or approved alternate	\$69.70	\$6,970.00	\$65.09	\$6,509.00	\$68.00	\$6,800.00
2.	100	1 1/2" Corporation Stop with nut Mueller B25000 or approved alternate	\$166.10	\$16,610.00	\$154.10	\$15,410.00	\$161.00	\$16,100.00
3.	100	2" Corporation Stop with nut Mueller B25000 or approved alternate	\$290.00	\$29,000.00	\$269.18	\$26,918.00	\$282.00	\$28,200.00
TOTAL			\$52,580.00	\$48,837.00	\$51,100.00			
Manufacturer/Model #			Mueller/Listed Model	Mueller	Ford			
Brass Fittings								
4.	100	1" x 3/4" CCU or 3-part Unions H-15400N Mueller or approved alternate	\$29.50	\$2,950.00	\$26.96	\$2,696.00	\$28.00	\$2,800.00
5.	100	1" CCU or 3-part Unions H-15400N Mueller or approved alternate	\$34.80	\$3,480.00	\$31.87	\$3,187.00	\$33.00	\$3,300.00
6.	100	1-1/2" CCU or 3-part Unions H-15400 Mueller or approved alternate	\$105.35	\$10,535.00	\$95.66	\$9,566.00	\$100.00	\$10,000.00
7.	100	2" CCU or 3-Part Unions H- 15400N Mueller or approved alternate	\$171.90	\$17,190.00	\$156.10	\$15,610.00	\$164.00	\$16,400.00
TOTAL			\$34,155.00	\$31,059.00	\$32,500.00			
Couplings								
8.	25	3/4" x 1" PBC or Piggy Back Coupling H-15062 Mueller or approved alternate	\$29.20	\$730.00	\$21.60	\$540.00	\$22.00	\$550.00
TOTAL			\$730.00	\$540.00	\$550.00			
Manufacturer/Model #			Mueller/Listed Model	Ay McDonald	Ford			

CITY OF TROY
 BID TABULATION
 WATER SYSTEM MATERIALS

Vendor Name:		Etna Supply	Core & Main LP	Ferguson Water Works
City:		Grand Rapids, MI	Shelby Twp., MI	Warren, MI

Curb Stops								
9.	100	1" CBS or Curb Stops Ford Z22 444M-NL or approved alternate	\$118.15	\$11,815.00	\$114.91	\$11,491.00	\$117.00	\$11,700.00
10.	100	1 1/2" CBS or Curb Stops Mueller B-25154N or approved alternate	\$279.60	\$27,960.00	\$250.80	\$25,080.00	\$263.00	\$26,300.00
11.	100	2" CBS or Curb Stops Mueller B-25154N or approved alternate.	\$452.25	\$45,225.00	\$405.76	\$40,576.00	\$425.00	\$42,500.00
TOTAL			\$85,000.00		\$77,147.00		\$80,500.00	
Manufacturer/Model #			Mueller/Listed Model		Ay McDonald		Ford	

Brass Bends								
12.	100	1 1/2"- 45 Degree Brass Bend Mueller H-15063N or approved alternate	\$103.10	\$10,310.00	\$100.49	\$10,049.00	\$98.00	\$9,800.00
13.	100	2"- 45 Degree Brass Bend Mueller H-15063N or approved alternate	\$190.50	\$19,050.00	\$185.71	\$18,571.00	\$181.00	\$18,100.00
14.	100	1"- 90 Degree Brass Bend Mueller H-15068N or approved alternate	\$37.25	\$3,725.00	\$36.35	\$3,635.00	\$36.00	\$3,600.00
15.	100	1 1/2" - 90 Degree Brass Bend Mueller H-15068N or approved alternate	\$119.10	\$11,910.00	\$116.13	\$11,613.00	\$113.00	\$11,300.00
16.	100	2" - 90 Degree Brass Bend Mueller H-15068N or approved alternate	\$222.90	\$22,290.00	\$217.29	\$21,729.00	\$212.00	\$21,200.00
TOTAL			\$67,285.00		\$65,597.00		\$64,000.00	
Manufacturer/Model #			Mueller/Listed Model		Mueller		Ford	
TOTAL LINE ITEM #2:			\$239,750.00		\$223,180.00		\$228,650.00	
GRAND TOTAL ALL ITEMS:			\$255,650.00		\$242,065.00		\$251,050.00	

ITEM #3: <u>Stainless Steel Repair Clamps</u> Single & Double Band, Solid and CC tap connections 1", 1 1/2", 2", Sizes 2" through 24" (US Manufactured, no iron lugs or bolts).			
Discount:	15%	50%	50%
Manufacturer:	Mueller	Romac (SS Series)	Ford Meter Box
Parts Price List:	Repair Clamps	Romac Price List	off
Date:	Time of Purchase	1/10/2011	1/1/2023

ITEM #4: <u>Brass Saddle</u> Brass Tap Saddles, 100% lead free, no steel bands, cc taps 3/4", 1", 1 1/2", 2", size ranges 4" through 24" (US Manufactured).			
Discount:	15%	45%	45%
Manufacturer:	Mueller	Mueller	Ford Meter Box
Parts Price List:	Brass Saddles	Mueller Service Saddles	
Date:	Time of Purchase	4/1/2019	1/1/2023

ITEM #5: <u>Stainless Steel Saddle</u> Stainless steel tap saddles (compatible with plastic, brass or stainless-steel pipe), 100% lead free, stainless steel bands, cc taps 3/4", 1", 1-1/2", 2", size ranges 4" through 24" (US Manufactured)			
Discount:	15%	50%	45%
Manufacturer:	Mueller	Powerseal	Ford Meter Box
Parts Price List:	SS Saddles	Powerseal Saddles	
Date:	Time of Purchase	N/A	1/1/2023

ITEM #6: <u>Mueller Complete Fire Hydrant & Valve Parts</u>			
Discount on Mueller complete fire hydrants:	0%	20%	25%
Discount:	15%	4%	25%
Manufacturer:	Mueller	Mueller	Mueller
Parts Price List:	Hydrant Parts	Mueller Blue	
Date:	Time of Purchase	2/9/2012	2/1/2012

CITY OF TROY
 BID TABULATION
 WATER SYSTEM MATERIALS

Vendor Name:	Etna Supply	Core & Main LP	Ferguson Water Works
City:	Grand Rapids, MI	Shelby Twp., MI	Warren, MI
Delivery:			
Company's minimum shipment:	0	N/A	NA
Days within phone request:	36 Week Lead Time	3 - 14 Days	300 Days
Hours of Operation:	7AM - 5PM	7:30 AM - 4:00 PM	7:00 - 5:00
24 Hour Phone No.:	(616) 245-4373	(586) 785-8851	(810) 691-2823
Contact Person:	Dalton Potgeter	Angela Caponi	David M Hobson
Descriptive Literature Provided: Y or N	N	Y	N
Payment Terms:	Net 30	Net 30	Net 30
Warranty:	Manufacturer	Manufacturer's Limited	Manufactures Warranty
Delivery:	36 Week Lead Time	3-4 weeks on curb boxes/ 17-19 weeks for most AY brass	1 - 210 days
Exceptions:	N/A	All "water service parts" quoted are AY McDonald with the exception of items #'s 12 -16 which are	None listed
Allow bid to be broken up: Y or N	N	Y	Y
Acknowledgement: Y or N	Y	Y	Y
Forms: Y or N	Y	Y	Y

Low Bidder Meeting Specifications

ATTEST:

(*Bid Opening conducted via a Zoom Meeting)

Theresa Shepard

Andrew Chambliss

Nellie Bert

Bryan Pompa

Emily Frontera

Purchasing Manager